

Fountain Classic™



Installation and Owner's Manual



4120 NW 44th Lincoln, NE 68524

www.mypurewater.com

402-467-9300

Table of Contents

Important Safety Information	4
Introduction	5
For the Record	5
Included With Your Distiller	5
Optional Accessories	5
Getting to Know the Fountain Classic	6
Installation	8
Maintenance	11
Post Filter Changing and Steam Sterilization	11
Cleaning the Boiling Chamber	12
Troubleshooting Guide	13
Wiring Schematic	14
Exploded Drawing 48998	15
Parts List 48998	16
Exploded Drawing 48999	17
Parts List 48999	18

Important Safety Information

IMPORTANT: *This distiller is designed to be used only with Pure Water, Inc. accessories and replacement components.*

- If you are not sure that your electrical outlet is properly grounded or that the circuit protection is correct, have it checked by a qualified electrician.
- Operate indoors only.
- The area must be well ventilated.
- **WARNING:** Disconnect from the power source before assembling, adjusting or servicing this appliance.
- **NEVER** immerse the distiller in water or any other liquid.
- **NEVER** operate the distiller with a damaged cord or allow the cord to become exposed to hot surfaces.
- **DO NOT** use an extension cord or any adapters.
- **DO NOT** let children play with the distiller.
- Wait at least 30 minutes after the distiller is off before draining or handling the boiling chamber.
- Do not run the dispenser water heater or water cooler when there is no water in the storage tank.
- The physiological effects of the operation of this distiller, beneficial or otherwise have not been investigated by U.L.
- The installation and use of this product must comply with all applicable state and local laws and regulations.
- If the unit was placed on its side for transport, be sure to allow the unit to stand upright for at least four hours before plugging unit in.
- Do not locate the unit in an area where the temperature falls below freezing.

Introduction

Congratulations on purchasing the finest water distillation system on the market. With proper care and attention, the Fountain Classic will give many years of top performance and high-quality drinking water. Please read this manual thoroughly before installing and operating your Fountain Classic.

For the Record

The model and serial number are found on the back panel. You should record all the necessary information below for future reference.

Date: _____

Model: **Fountain Classic** _____

Serial Number: _____

Purchased from: _____

Telephone: _____

Included with Your Distiller

- **Incoming Water Hook-up.** Includes:
Saddle tapping valve (Part # 9514)
15 feet of 1/4" food-grade tubing (Part # 9526-15R)
1/4"S x 1/4"T speedfit elbow (Part # 221-9006)
- **Post Filter.** Includes:
Post filter (Part # 9406A)
(2) 3/8"T x 3/8"S speedfit elbows (Part # 9614)
Silicone tubing (Part # 9541)
- **Power cord*** (May not be included in some 240V units)
(US version Part # 7276)
*For 240V units, power cord must be at least 10 Amp
at 240V grounded cord
- **Owners Manual** (Not shown) (Part # 6338)
- **Warranty Card** (Not shown)

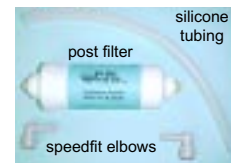
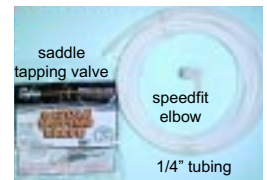

Optional Accessories

- **Distiller Day Timer.** Allows you to limit the hours of water production. (Part # 733)
- **Cup Dispenser, Metal.** (Part # 110-9031)
- **Lumen™ Cleaner and Descaler** for cleaning the boiling tank. (Part # 6603)
- **5 oz. Cups.** (Part # 110-9032)
- **Stainless steel polish.** (Part # 6606)
- **Post filter replacement cartridge.** (Part # 9406A)
- **Pump kit** to attach the pump for icemaker hookup. (Part # 735)

Getting to Know the Fountain Classic

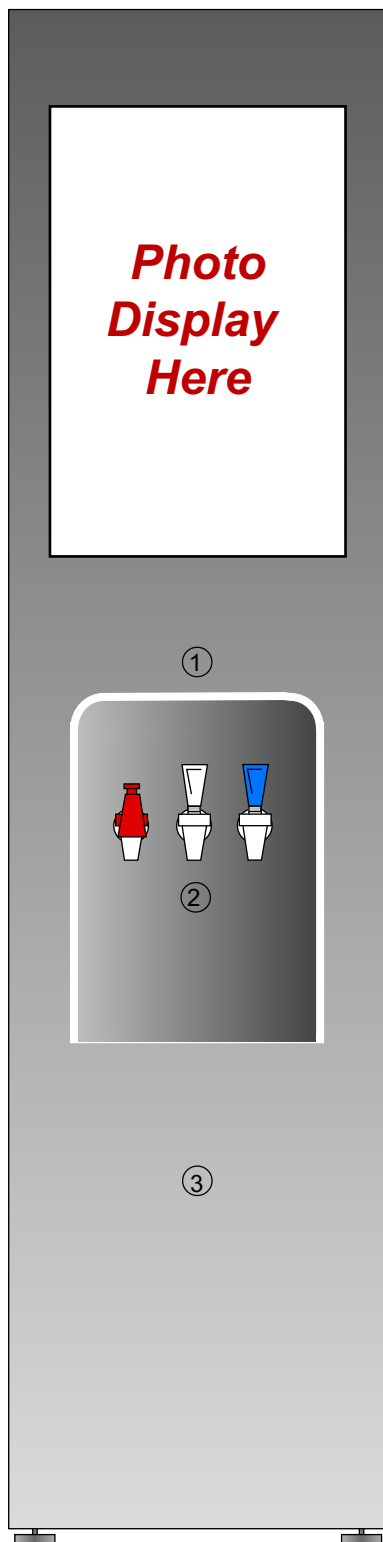

1. **Photo Display**—This is a backlit area to display photos or advertising. Several optional displays are available from Pure Water, Inc. or from your local distributor.
2. **Water Dispensing Area**—Three temperature units have dispensers for Hot Water, Room Temperature Water, and Cold Water and the two temperature unit has dispensers for Room Temperature Water and Cold Water. The Controls for these are listed in items 14 and 15.
3. **Drip Tray**—The hidden drip tray collects water that spills from the Dispensing Area. This must be routinely emptied to prevent overflows and spillage.
4. **Water Inlet**—Raw water from the local supply enters the machine at this location. It is important to use the cold water supply.
5. **Water Inlet Solenoid**—This valve automatically opens to allow water to flow into the Boiling Chamber when the water level is low.
6. **Removable Boiling Chamber**—This is where the raw water is heated to boiling. Contaminants from the water stay in this chamber. It is important that this chamber is drained and periodically cleaned of residue per instructions. For more information see page 11.
7. **Heating Element**—This heating element heats the raw water to boiling. The standard heating element is 1400 Watts.
8. **Safety Reset**—This mechanical safety feature ensures that if the heating element continues when not covered with water, the unit will turn off automatically.
9. **Boiling Chamber Drain Valve**—As the steam evaporates from the raw water, the contaminants in the water in the boiling chamber can become very concentrated. This valve allows you to drain the contaminants off, so that they do not build up.
10. **Steam Tube**—The steam created in the boiling chamber rises through this tube to the condensing coil at the top of the unit.
11. **Condensing Coil and Fan Assembly**—The steam from the steam tube enters the condensing coil. The fan turns on, and sends cooling air past the coil. The steam is cooled and condenses to distilled water. The condensing coil has two small volatile gas vents to allow the volatile gases to escape.

12. **Post Filter**—The carbon filter enhances the flavor of the distilled water before it enters the storage tank.
13. **Distilled Water Storage Tank**—This tank holds distilled water for use through any of the water spigots. This tank contains floats that turn the distiller off when full, and turns the distiller back on when the tank is 1/3 empty.
14. **Water Dispenser Section**—This section is composed of either two or three main sections, depending on your unit:
- The hot water tank holds up to 3/8 gallon, and quickly heats the water for use at the hot water spigot. The hot water temperature is adjustable from 140°F to 190°F. (Three temperature unit only)
 - The cold water tank holds up to 3/4 gallon, and chills the water for use at the cold water spigot. The cold temperature is adjustable from 40°F to 50°F.
 - The reservoir holds up to 9.25 gallons for use at the room temperature water spigot. The water is at room temperature.

15. **Dispenser Hot Water Switch***—This switch allows the dispenser to heat the water for the hot water spigot.

Important: This switch must be in the OFF position until the storage tank is filled the first time.

***Three temperature unit only**

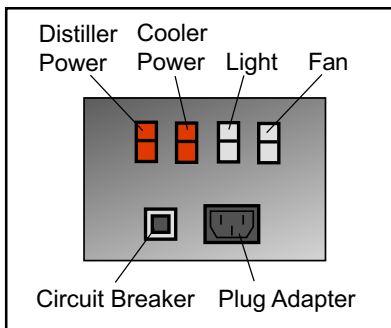

16. **Main Electrical Control Box**—This electrical box has all of the controls for the unit.

Distiller Power Switch—Controls the power for the distillation unit.

Cooler Power Switch—Controls the power to the cooler and hot tank.

Light Power Switch—Turns the lighted display panel on the front of the unit on.

Fan Power Switch—This switch is used to either

Steam Sterilize (when the switch is off), or distill (when the switch is on).

Steam Sterilizing instructions are found on page 10.

Circuit Breaker—This breaker provides electrical circuit protection for the unit.

Plug Adapter—This plug provides power for the entire unit through the power cord.

17. **Emergency Overflow Float**—Turns the unit off automatically if water fills the bottom pan.

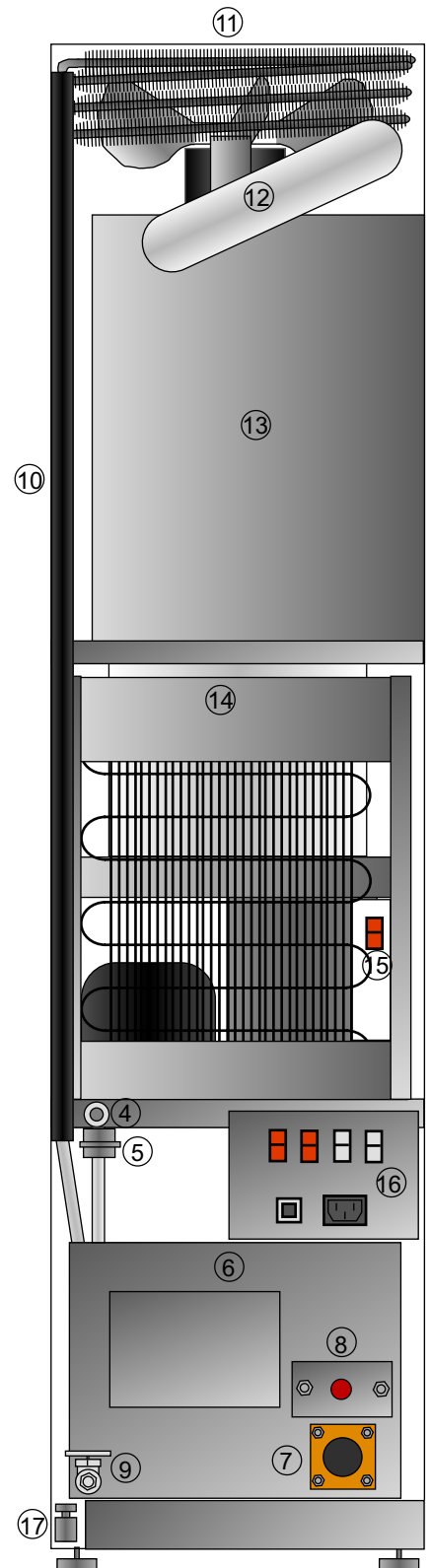

Installation

CAUTION:	DO NOT use a hot water line for the raw water supply.
CAUTION:	DO NOT turn the saddle tapping valve handle before or during installation. Be sure the piercing lance does not protrude beyond the rubber gasket. Failure to do this may result in damage to the piercing needle.
NOTE:	The use of softened water for the raw water supply is recommended to minimize scale buildup in the boiling tank and drain valve.
NOTE:	The Fountain Classic comes standard with a saddle-tapping valve. In some areas a saddle-tapping valve may not be permitted. In such instances, contact your authorized Pure Water Distributor for other water line connection options.
NOTE:	Do not plug the unit into the power source until instructed to do so.

The installation of the Fountain Classic is very simple. The steps are as follows:

1. Position the unit in a well ventilated area.
2. Connect the unit to the water supply so that it can operate automatically.
3. Plug the unit into an appropriate power plug.
4. Start the machine.
5. Install the Photo Display
6. Steam Sterilize the machine.
7. Start Distillation.
8. Rinse the Post Filter.
9. Turn the dispensing unit on.

Step 1 Positioning the unit

The unit should be positioned on a level floor that has an appropriate electrical plug and water supply available. If the ground is not completely level, the leveling feet on the bottom of the unit can be used to adjust the machine.

Note: The Fountain Classic must be positioned on a level surface. Allow at least 2" of clearance behind unit for proper air circulation.

Step 2 Connecting the water supply:

This unit comes complete with a saddle-tapping valve to connect the distiller water inlet directly to an existing waterline.

Connecting the Saddle Tapping Valve:

1. Turn the raw water supply off.
2. Install the saddle tapping valve on the COLD water copper tubing so the outlet is in a convenient direction. See figure.
3. Tighten screws evenly. Brackets should be parallel. Tighten firmly. Do not over tighten.
4. Connect tubing to the saddle tapping valve outlet.
5. Plug the other end of the 1/4" tubing into the Raw Water Inlet on the back of the Fountain Classic.

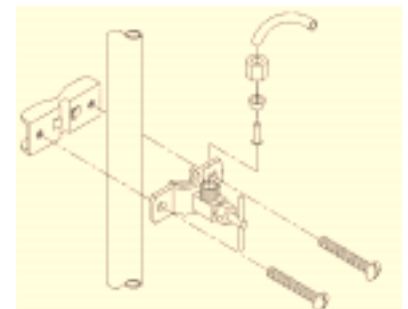

Saddle Tapping Valve

6. Turn the saddle tapping valve handle clockwise until you feel it is firmly seated.
Note: *You have now pierced the copper tube and the valve is closed.*
7. Turn the handle counterclockwise to open the valve. Turn the household water supply ON and check all connections for leaks.
8. Open the saddle tapping valve completely. Check the line for leaks. Tighten where required.

Step 3 Plug the unit into an appropriate power plug:

Locate the power cord in the parts kit bag. Make sure that the electrical outlet rating exceeds the requirements for this unit (15 Amp dedicated circuit). Install the female end of the power cord into the adapter on the main electrical control box. Plug the unit into the wall outlet.

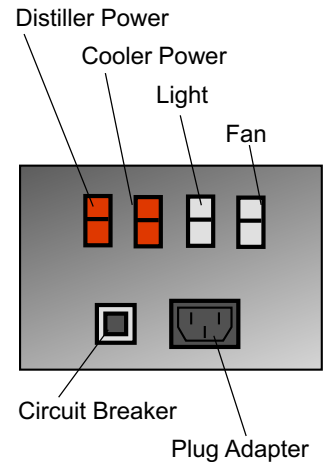

Step 4 Start the Machine:

Before starting the machine the switches should be in the following positions:

Distiller Power:	OFF
Fan Switch:	OFF
Light Switch:	OFF
Cooler Power:	OFF
Dispenser Hot Water Switch*:	OFF

***Three temperature unit only**

Now the distiller power can be turned on. The unit will energize. The boiling tank will automatically begin to fill with water and start to heat up.

WARNING: *Never turn the dispenser hot water switch on without water in the hot tank. (Three temperature unit only)*

Step 5 Installing the Photo Display:

The cooler transparency will be packed separately and require installation.



To install the color transparency:

1. Remove the screws in the top panel of the unit. Remove the top panel.
2. Slide the plastic transparency cover up and out of the unit.
3. Place the 2 bulbs into their sockets. Turn into place.
4. Place transparency behind the transparency cover and lower into place.
5. Replace the top panel and screw into place.

Now you can turn the light switch ON.

Step 6 Steam Sterilization of the Machine:

Use the high temperature tubing, included in the parts kit in place of the post filter. It will connect the outlet end of the condensing coil to the storage tank inlet. This tube must be used because the post filter cannot withstand the temperature of the steam. Now the boiling chamber is creating steam. The steam will rise up to the condensing coil. Normally the fan would cool the steam and it would change back to water form. The fan switch is turned off, so there is no way for the steam to cool and condense. Steam will be sent to the storage tank. This will heat the tank and kill any bacteria in the machine. Once you can see that steam is being created, allow the unit to steam for 25 minutes. (Total time spent is approximately 1 hour.)



Step 7 Distillation:

After the unit has adequately steam sterilized, turn the Fan switch to the ON position. The fan will start and begin to cool the steam. After a few minutes, distilled water will be created.



Step 8 Rinse the Post Filter:

Remove the high temperature tubing used for Steam Sterilization. Connect the Post Filter to the condensing coil outlet and the storage tank inlet. There is an arrow on the side of the filter that indicates the proper direction of the post filter. Allow the unit to distill for 5-6 hours. Using the spigots in the front, empty the water from the unit. This water should be discarded. **(Three temperature unit owners: *be sure to draw water from the hot water spigot so any air in the lines or tank is released.*)**



Step 9 Turn the dispensing unit on:

Allow the distiller to operate for an additional 5-6 hours. Several gallons of water will be in the storage tank. It is now safe to turn the Cooler Power switch to ON, and the Dispenser Hot Water Switch to ON. *(Three temperature unit only.)*

Maintenance

IMPORTANT: This tube must be used, because the post filter cannot withstand the temperature of the steam.

Post Filter Changing and Steam Sterilization

Every 2000 operating hours (3 months if the unit is operating continuously):

Step 1 Empty the Distiller:

It is very important that the storage tanks are empty before steam sterilization takes place. To do this:

1. Turn power OFF to the unit.
2. Turn the dispenser power OFF.
3. Turn the Dispenser Hot Tank Switch to OFF. *(Three temperature unit only.)*
4. Attach tubing to each of the dispensing spigots and drain all of the water to a floor drain or suitable container.

Step 2 Steam Sterilization:

1. Remove the old post filter from the unit.
2. Place the piece of high temperature tubing in place of the post filter. It will connect the outlet end of the condensing coil to the storage tank inlet.
3. Turn the power to the unit ON. Now the boiling chamber is creating steam. The steam will rise up to the condensing coil.
4. Turn the fan switch to the OFF position. The steam will not cool and condense, so steam will be sent to the storage tank. This will heat the tank and kill any bacteria in the machine.
5. Once you can see that steam is being created, allow the unit to steam for 25 minutes.
6. Turn the Fan switch to the ON position. The fan will start and begin to cool the steam. After a few minutes distilled water will start to be created.



Step 3 Rinse the Post Filter:

1. Remove the high temperature tubing.
2. Connect the Post Filter to the condensing coil outlet and the storage tank inlet. There is an arrow on the side of the filter that indicates the proper direction of the post filter.
3. Allow the unit to distill for 5-6 hours.
4. Using the spigots in the front, empty the water from the unit. This water should be discarded.



Step 4 Turn the dispensing unit on:

1. Allow the distiller to operate for an additional 5-6 hours. Several gallons of water will be in the storage tank.
2. Turn the Cooler Power switch to ON.
3. Turn the Dispenser Hot Water Switch to ON. *(Three temperature unit only)*

Cleaning the Boiling Chamber

Every 2000 hours or every three months:

Step 1 Shutdown and Cooling:

1. Turn the distiller switch to the OFF position and unplug unit.
2. Allow the boiling chamber to cool down.
3. Turn the unit so that the rear is accessible.
4. Remove 4 screws and take off rear access panel.
5. Disconnect the tubing to the boiling chamber.
6. Disconnect the electrical connections to the boiling chamber.
7. Pull the boiling chamber out of the unit.
8. Drain into a sink.
9. Fill the boiling chamber with water to the top of the scale line.
10. Add 4-6 tablespoons of Lumen™ descaling powder to the boiling chamber.
11. Allow the lumen to soften any scale (allow 12-24 hours for scale to soften).
12. Drain and rinse boiling chamber.
13. Reconnect tubing and electrical connections.
14. Turn the distiller switch to the ON position.

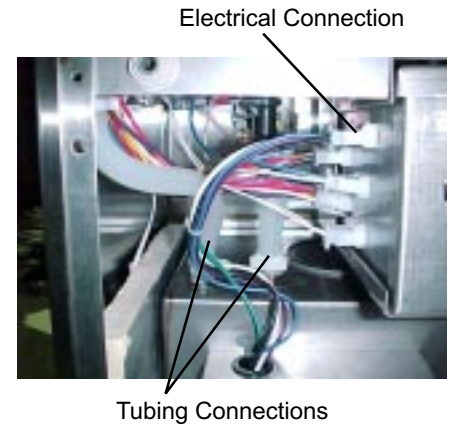

Troubleshooting Guide

Symptom	Probable Cause	Solution
Unit does not operate.	Unit not plugged in.	Plug unit into power source.
	Power failure, circuit breaker or fuse blown.	Reset breaker or replace fuse.
	Power switch OFF.	Turn power switch ON.
Unit runs, but exhaust is cool.	Heating element failure.	Replace the heating element.
	Reset tripped.	Push in the reset button.
Water has bad smell or taste.	Post filter is depleted or carry-over problem.	Replace the post filter. Drain the boiling tank.
Unit makes a hissing noise.	Faulty heating element or fan.	Adjust or Replace.
	Improper air flow.	Position unit in a well ventilated area.
Dispenser not cooling.	No coolant in compressor.	Call for service.
	Cold temperature control.	Adjust or Replace.
No hot water from dispenser. <i>(Three temperature unit only.)</i>	Hot water switch turned OFF.	Turn switch ON when distilled water tank is full.
	Hot temperature control.	Adjust or Replace.
Leaking of any kind.	Various.	Disconnect power and shut off the feed water supply. Call for immediate service.

Wiring Schematic

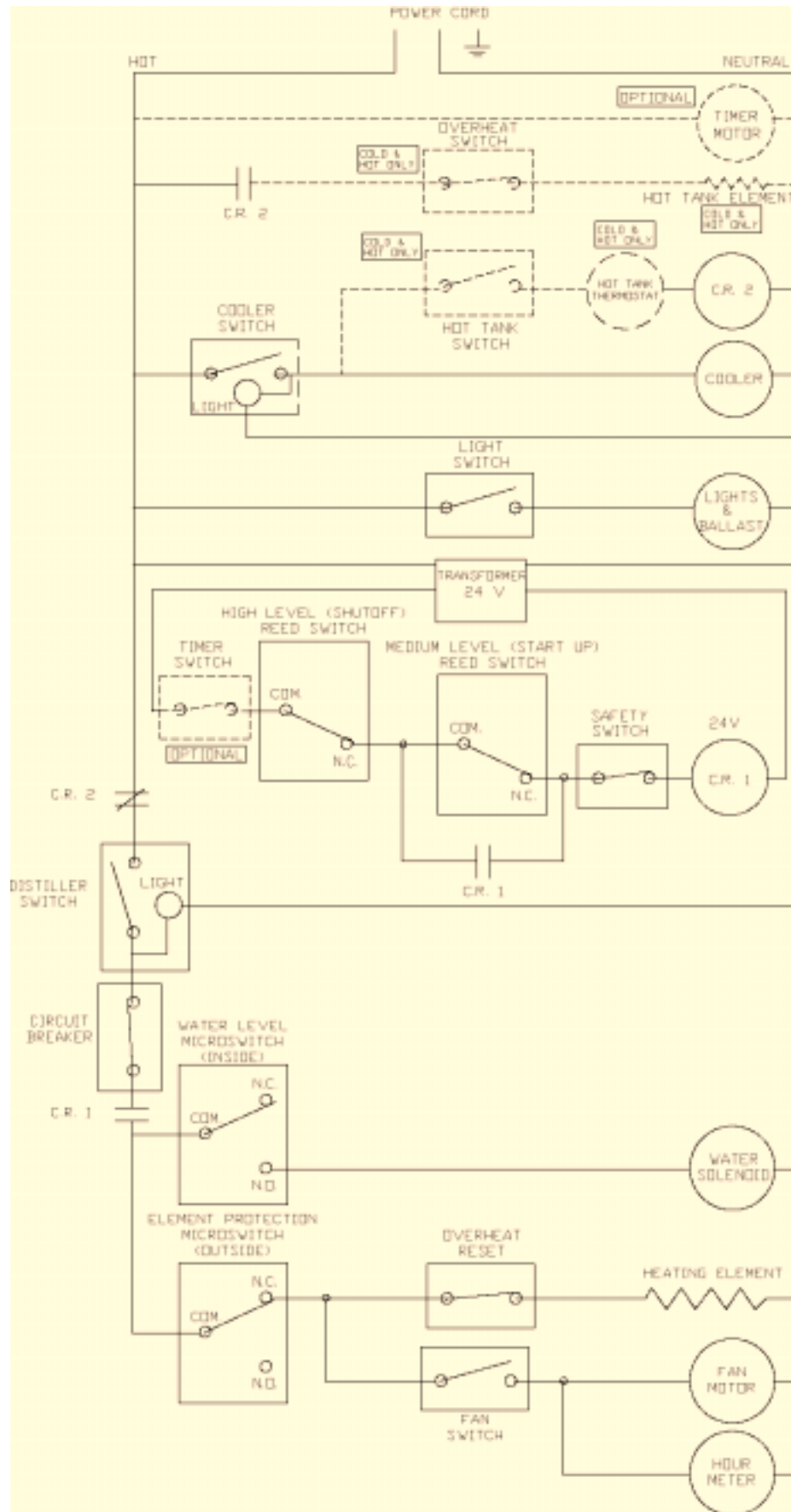

Exploded Drawing: 48998 Two Temperature Unit

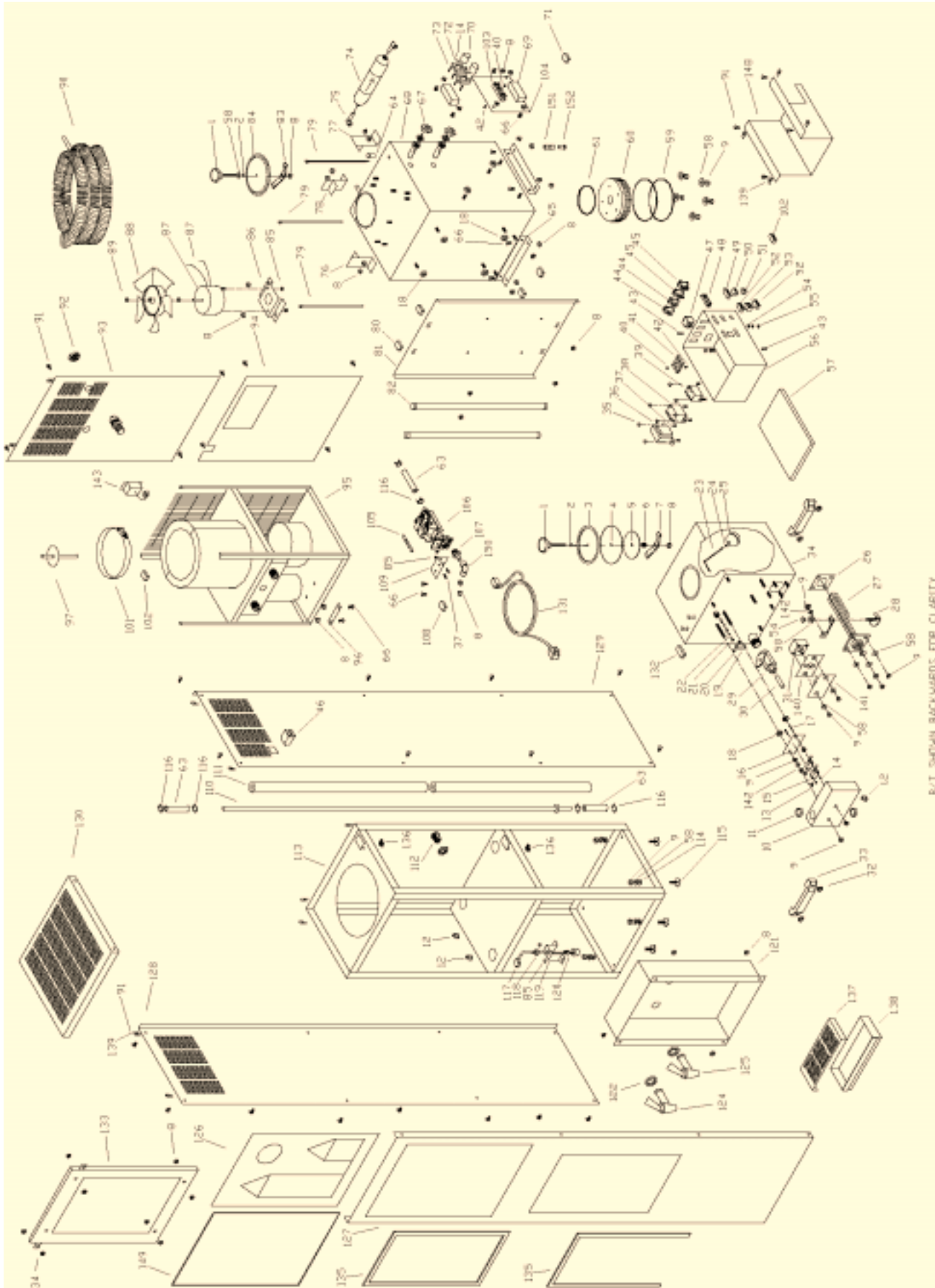

FOR OUTLINE DRAWINGS SEE CLARITY

Parts List

Key #	120V P/N	240V P/N	Description
1	8009	8009	Lid Knob with Stud
2	6022	6022	Lid O-Ring
3	519	519	Lid Disc
4	69	69	Lid Gasket
5	533	533	Gasket Retainer
6	9085	9085	Lid Spring
7	402B	402B	Lid Crossbar with Nut
8	224-0003	224-0003	Locknut, 1/4-20
*	406	406	Lid Assy (Includes #1-8)
9	9045	9045	Nut, 1/4-20
10	48003	48003	Switch Cover
11	9220	9220	Bushing, 1" Plastic
12	7230	7230	Wire Holder
13	7127	7127	Tab, Adapt.
14	9041	9041	Hex Nut, 4-40
15	7200	7200	Microswitch
16	516	516	Switch Plate
17	9030	9030	Screw, 4-40 x 1-1/8"
18	8070	8070	Nylon Spacer
*	662	662	Microswitch Kit (Includes #14-#18)
19	9082	9082	Actuating Arm
20	9024	9024	Set Screw
21	9080	9080	Float Bushing, Teflon
22	6021	6021	Float O-ring
*	604	604	O-Ring and Bushing Kit (Includes #21 and #22)
23	513	513	Float Rod
24	9018	9018	#6 Hex Nut
25	9519	9519	Float Ball
*	644	644	Float Kit (Includes #19-#25)
26	6005	6005	Heating Element Gasket
27	9303	9303V	Heating Element (1400W)
28	400A-02	400A-02	Clamp, Studded, Heating Element Kit #601
*	727	727V	Heating Element Kit (Includes #26-#28, 54, 58)
29	9302	9302	Drain Valve
30	48018	48018	Drain Tube
31	7069	7069	Reset, Heating Element Kit #601
32	9079	9079	Nut, Acorn
33	9108	9108	Handle, Polymide
34	48502-02	48502-02	Boiling Tank, Welded
35	9043	9043	Hex Nut, #8
36	9314	9314V	Transformer
37	9095	9095	Screw, #8
38	9316	9316	Relay, 24V, DPST
39	7206	7206V	Relay, SPDT
40	9018	9018	Hex Nut, #6
41	9110	9110	Buss Connector, 8 x 8
42	9023	9023	Screw, #6
43	9059	9059	Screw, #10
44	7228	7228	Switch, On/Off *Kit #642
45	7232	7232	Switch, Lighted *Kit #648
46	219-0227	219-0227	Hour Meter
47	7275	7275	Connector IEC
48	9315	9412	Circuit Breaker, Resetable
49	7129	7129	Conn, 5 Pin Female
50	7133	7133	Conn, 3 Pin Female
51	7136	7136	Conn, 2 Pin Female
52	7148	7148	Conn, 4 Pin Female
53	7139	7139	Conn, 6 Pin Female
54	9046	9046	Washer, Lock #10
55	9061	9061	Hex Nut, #10
56	48503-01	48503-01	Welded Elec. Box
57	48032	48032	Elec. Box Lid
58	9009	9009	Washer, Flat, 1/4"
59	9310	9310	6" O-ring
60	9301	9301	Coupler, Plastic
61	9311	9311	5" O-Ring
63	9541	9541	Silicone Tubing
64	8014	8014	Air Filter
65	48019	48019	Bracket, S/T
66	223-0002	223-0002	Screw, 1/4-20
67	110-9057	110-9057	Storage Tank Float Kit # 677
68	48506-02	48506-02	Storage Tank, Studded
69	9323	9323V	Light Ballast *Kit # 731 & #731V
70	9321	9321V	Starter *Kit #732 & #732V
71	7138	7138	Conn, 6 Pin Male
72	9322	9322	Starter Base
73	9001	9001	Screw, #4
74	9406	9406	Filter, Carbon *Kit #9406A
Key #	120V P/N	240V P/N	Description

75	9614	9614	Elbow, 3/8"
76	48507	48507	Short Coil Bracket
77	48508	48508	Med. Coil Bracket
78	48509	48509	Tall Coil Bracket
79	7246	7246	Cable Tie, Black
80	9324	9324	Lamp Holder
81	48040	48040	Light Housing
82	9320	9320	Light Bulb *Kit #730
83	402C-01	402C-01	Crossbar, S/T
84	548	548	Lid, Storage Tank
*	410A	410A	Lid, S/T (Includes #1,2,8,58,83,84)
85	9003	9003	Nut, #8 Nylock
86	541	541	Fan Bracket
87	7092	70103A	Fan Motor
88	7010	7010	Fan Blade
89	9092	9092	Push Nut
*	639	639	Fan Blade Kit (Includes #88 & #89)
*	653	653V	Fan and Motor Kit (Includes #87-#89)
90	9304	9304	Condensing Coil *Kit #729
91	9029	9029	Sheetmetal Screw, #10
92	7026	7026	Connector, Gray, 3/8"
93	48028	48028	Top Back Panel
94	48029	48029	Bottom Back Panel
95	48517A	48517AV	Compressor Assy. Room & Cold
96	48044	48044	Cooler Bracket
97	45518	45518	Cooler Baffle
101	9317	9317	T-Bar Clamp, 6"
102	7147	7147	Conn. 4 Pin Male
103	9111	9111	Buss Connector, 2x3x4
104	48041	48041	Ballast Plate
105	9526	9526	Tubing, 1/4" OD
106	7219	7219V	Inlet Solenoid Valve *Kit #728 & #728V
107	9638	9638	Elbow, Speedfit, 3/8" x 1/4"
108	7134	7134	Conn. 3 Pin Male
109	48039	48039	Valve Bracket
110	48501	48501	Welded Steam Tube
111	48030	48030	Insulation, Set, B/T and Pipe
112	221-9000	221-9000	Speedfit, Bulkhead
113	48504	48504	Welded Frame
114	6049	6049	Rubber Washer
115	9592	9592	Adjustable Leg
116	6103	6103	Hose Clamp, Plastic
117	7132	7132	Conn. 2 Pin Male
118	9048	9048	Nut, 1/8" MPT
119	32029	32029	Bracket, Float
120	213-0037	213-0037	Safety Float
121	48521A	48521A	Welded Faucet Bracket, 2 Hole
122	9319	9319	Rubber Washer
124	9306	9306	White Faucet
125	9305	9305	Blue Faucet
126	9325	9325	Graphic
127	48513	48513	Front Cladding
128	48024C	48024C	Left Cladding
129	48024B	48024B	Right Cladding
130	48025	48025	Top Cladding
131	7276	**	Power Cord
132	7128	7128	Conn. 5 Pin Male
133	48505	48505	Welded Frame
134	9408	9408	Nylon Spacer
135	6070	6070	Wire Trim
136	9328	9328	Wire Clip
137	48027	48027	Drip Pan Cover
138	48512	48512	Drip Pan
139	9047	9047	Clip, J Type
140	510	510	Reset Plate, Insulated
141	424A	424A	Reset Plate, SS
142	9032	9032	Lock Washer, 1/4"
143	9332	9332	Compressor Thermostat
148	48036	48036	Electrical Box Support
149	9326	9326	Plastic Graphic Cover
150	9605	9605	Elbow, Speedfit, 3/8" x 1/4"
151	9621	9621	Connector, Speedfit, 3/8"X1/4"
152	221-0056	221-0056	Plug, 3/8", Speedfit
**	48525	48525	Wire Kit
**	Parts Kit		
**	Sold Separately		
***	Not Shown		

Exploded Drawing: 48999 Three Temperature Unit

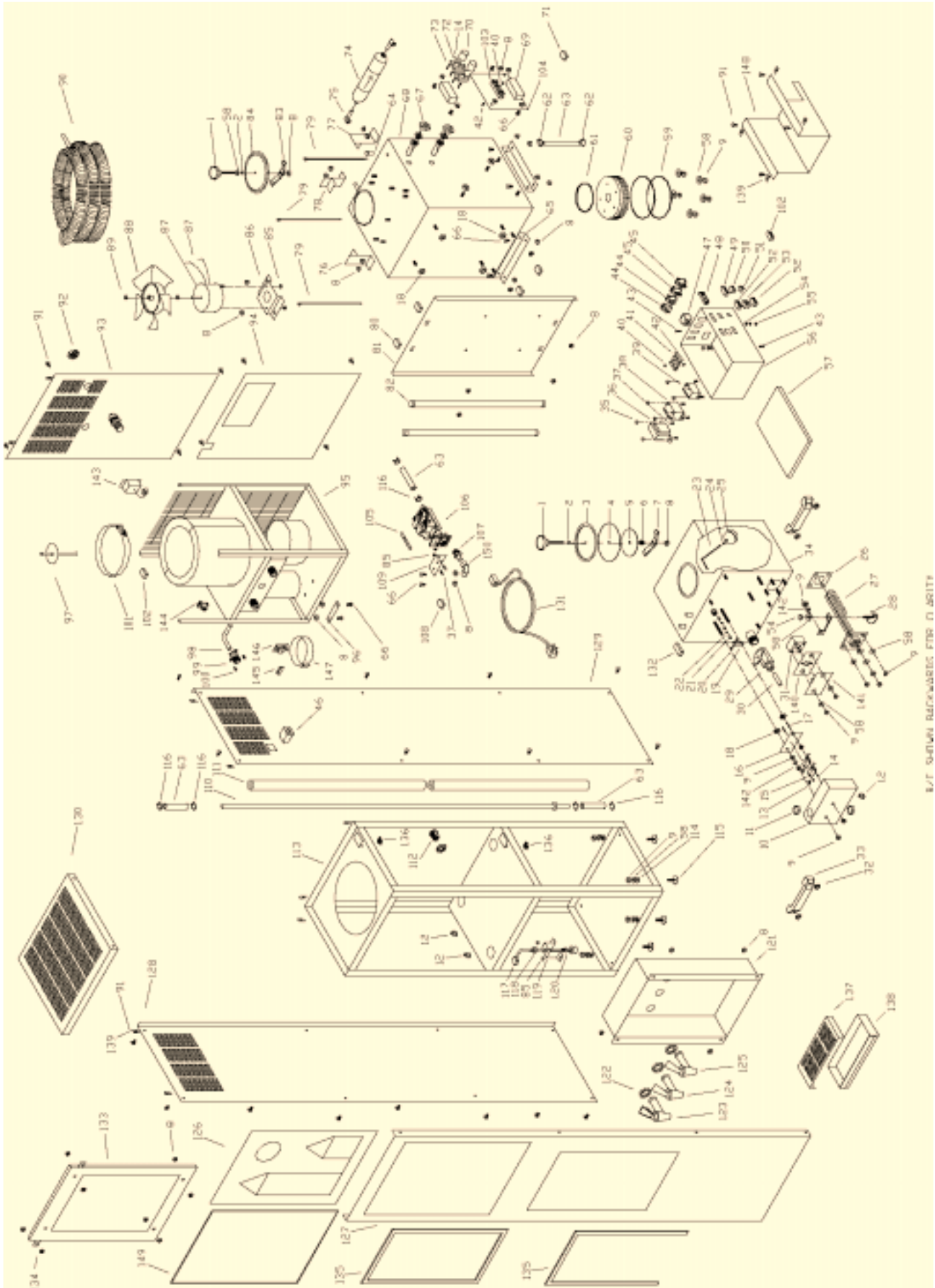

Parts List

Key #	120V P/N	240V P/N	Description
1	8009	8009	Lid Knob with Stud
2	6022	6022	Lid O-Ring
3	519	519	Lid Disc
4	69	69	Lid Gasket
5	533	533	Gasket Retainer
6	9085	9085	Lid Spring
7	402B	402B	Lid Crossbar with Nut
8	224-0003	224-0003	Locknut, 1/4-20
*	406	406	Lid Assy (Includes #1-8)
9	9045	9045	Nut, 1/4-20
10	48003	48003	Switch Cover
11	9220	9220	Bushing, 1" Plastic
12	7230	7230	Wire Holder
13	7127	7127	Tab, Adapt.
14	9041	9041	Hex Nut, 4-40
15	7200	7200	Microswitch
16	516	516	Switch Plate
17	9030	9030	Screw, 4-40 x 1-1/8"
18	8070	8070	Nylon Spacer
*	662	662	Microswitch Kit (Includes #14-#18)
19	9082	9082	Actuating Arm
20	9024	9024	Set Screw
21	9080	9080	Float Bushing, Teflon
22	6021	6021	Float O-ring
*	604	604	O-Ring and Bushing Kit (Includes #21 and #22)
23	513	513	Float Rod
24	9018	9018	#6 Hex Nut
25	9519	9519	Float Ball
*	644	644	Float Kit (Includes #19-#25)
26	6005	6005	Heating Element Gasket
27	9303	9303V	Heating Element (1400W)
28	400A-02	400A-02	Clamp, Studded, Heating Element Kit #601
*	727	727V	Heating Element Kit (Includes #26-#28, 54, 58)
29	9302	9302	Drain Valve
30	48018	48018	Drain Tube
31	7069	7069	Reset, Heating Element Kit #601
32	9079	9079	Nut, Acorn
33	9108	9108	Handle, Polymide
34	48502-02	48502-02	Boiling Tank, Welded
35	9043	9043	Hex Nut, #8
36	9314	9314V	Transformer
37	9095	9095	Screw, #8
38	9316	9316	Relay, 24V, DPST
39	7206	7206V	Relay, SPDT
40	9018	9018	Hex Nut, #6
41	9110	9110	Buss Connector, 8 x 8
42	9023	9023	Screw, #6
43	9059	9059	Screw, #10
44	7228	7228	Switch, On/Off *Kit #642
45	7232	7232	Switch, Lighted *Kit #648
46	219-0227	219-0227	Hour Meter
47	7275	7275	Connector IEC
48	9315	9412	Circuit Breaker, Resetable
49	7129	7129	Conn, 5 Pin Female
50	7133	7133	Conn, 3 Pin Female
51	7136	7136	Conn, 2 Pin Female
52	7148	7148	Conn, 4 Pin Female
53	7139	7139	Conn, 6 Pin Female
54	9046	9046	Washer, Lock #10
55	9061	9061	Hex Nut, #10
56	48503-01	48503-01	Welded Elec. Box
57	48032	48032	Elec. Box Lid
58	9009	9009	Washer, Flat, 1/4"
59	9310	9310	6" O-ring
60	9301	9301	Coupler, Plastic
61	9311	9311	5" O-Ring
62	9922	9922	Hose Clamp
63	9541	9541	Silicone Tubing
64	8014	8014	Air Filter
65	48019	48019	Bracket, S/T
66	223-0003	223-0002	Screw, 1/4"-20
67	110-9057	110-9057	Storage Tank Float Kit # 677
68	48506-02	48506-02	Storage Tank, Studded
69	9323	9323V	Light Ballast *Kit # 731 & #731V
70	9321	9321V	Starter *Kit #732 & #732V
71	7138	7138	Conn, 6 Pin Male
72	9322	9322	Starter Base
73	9001	9001	Screw, #4
74	9406	9406	Filter, Carbon *Kit #9406A
75	9614	9614	Elbow, 3/8"

Key #	120V P/N	240V P/N	Description
76	48507	48507	Short Coil Bracket
77	48508	48508	Med. Coil Bracket
78	48509	48509	Tall Coil Bracket
79	7246	7246	Cable Tie, Black
80	9324	9324	Lamp Holder
81	48040	48040	Light Housing
82	9320	9320	Light Bulb *Kit #730
83	402C-01	402C-01	Crossbar, S/T
84	548	548	Lid, Storage Tank
*	410A	410A	Lid, S/T (Includes #1,2,8,58,83,84)
85	9003	9003	Nut, #8 Nylock
86	541	541	Fan Bracket
87	7092	70103A	Fan Motor
88	7010	7010	Fan Blade
89	9092	9092	Push Nut
*	639	639	Fan Blade Kit (Includes #88 & #89)
*	653	653V	Fan and Motor Kit (Includes #87-#89)
90	9304	9304	Condensing Coil *Kit #729
91	9029	9029	Sheetmetal Screw, #10
92	7026	7026	Connector, Gray, 3/8"
93	48028	48028	Top Back Panel
94	48029	48029	Bottom Back Panel
95	48517	48517V	Compressor Assy.
96	48044	48044	Cooler Bracket
97	45518	45518	Cooler Baffle
98	48007	48007	Elbow, 3/8"
99	9318	9318	Plastic Connector
100	9033	9033	Screw, #6
101	9317	9317	T-Bar Clamp, 6"
102	7147	7147	Conn. 4 Pin Male
103	9111	9111	Buss Connector, 2 x 3 x 4
104	48041	48041	Ballast Plate
105	9526	9526	Tubing, 1/4" OD
106	7219	7219V	Inlet Solenoid Valve *Kit #728 & #728V
107	9638	9638	Elbow, Speedfit, 3/8" x 1/4"
108	7134	7134	Conn. 3 Pin Male
109	48039	48039	Valve Bracket
110	48501	48501	Welded Steam Tube
111	48030	48030	Insulation, Set, B/T and Pipe
112	221-9000	221-9000	Speedfit, Bulkhead
113	48504	48504	Welded Frame
114	6049	6049	Rubber Washer
115	9592	9592	Adjustable Leg
116	6103	6103	Hose Clamp, Plastic
117	7132	7132	Conn. 2 Pin Male
118	9048	9048	Nut, 1/8" MPT
119	32029	32029	Bracket, Float
120	213-0037	213-0037	Safety Float
121	48521	48521	Welded Faucet Bracket
122	9319	9319	Rubber Washer
123	9307	9307	Red Faucet
124	9306	9306	White Faucet
125	9305	9305	Blue Faucet
126	9325	9325	Graphic
127	48513	48513	Front Cladding
128	48024C	48024C	Left Cladding
129	48024B	48024B	Right Cladding
130	48025	48025	Top Cladding
131	7276	**	Power Cord
132	7128	7128	Conn. 5 Pin Male
133	48505	48505	Welded Frame
134	9408	9408	Nylon Spacer
135	6070	6070	Wire Trim
136	9328	9328	Wire Clip
137	48027	48027	Drip Pan Cover
138	48512	48512	Drip Pan
139	9047	9047	Clip, J Type
140	510	510	Reset Plate, Insulated
141	424A	424A	Reset Plate, SS
142	9032	9032	Lock Washer, 1/4"
143	9332	9332	Compressor Thermostat
144	9331	9331	Switch, Hot Tank
145	9334	9334	Limitter, Hot Tank
146	9330	9330	Hot Tank Thermostat
147	9333	9333V	Hot Tank Heater
148	48036	48036	Electrical Box Support
149	9326	9326	Plastic Graphic Cover
150	9605	9605	Elbow, Speedfit, 3/8" x 1/4"
***	48525	48525	Wire Kit

* Parts Kit

** Sold Separately

*** Not Shown

Form #6338, ©2000, Pure Water, Inc.

U.S. and Foreign Patents Pending