

FOR THE RECORD

The model and serial number are found on the back panel. You should record both the model and serial number from the back of the machine for future reference.

Model MINI-CLASSIC CT

Date of Purchase _____

Serial Number _____

Dealer Name and Phone Number _____

ORDERING PARTS & SERVICING

Pure Water recommends that you have your Pure Water Mini-Classic CT serviced by an authorized service center. Please see your Pure Water Dealer or Distributor.

If you require parts or accessories at any time, please contact your Pure Water Dealer or Distributor. In the unlikely event your Pure Water Dealer or Distributor cannot help, you may contact Pure Water Customer Service at 800-875-5915.

To help you identify parts for your Pure Water Mini-Classic CT please see the parts list included in this manual on page 14.

Pure Water

MINI-CLASSIC CT™

Water Distiller

Owners Manual



4120 NW 44th, Lincoln, NE 68524 USA
Phone: 402-467-9300 • Fax: 402-467-9393 www.mypure-water.com

CONTENTS

Congratulations from the President of Pure Water3

Important Safety Information3

Use and Care of the Drinking Water Container4

Electrical Requirements.....4

How Distillation and Your Distiller Work.....5

Getting Acquainted With Your Mini-Classic CT6-7

Unpacking Your Mini-Classic CT8

First Time Start-Up 8-9

Normal Operation9

Maintenance & Cleaning 10-11

- Maintenance
- Cleaning
- Replacing the Carbon Filter

Troubleshooting12-13

Individual Parts List 14

Exploded View of Mini-Classic CT 15

For the Record..... back cover

Ordering Parts and Servicing back cover

Exploded View of Mini-Classic CT

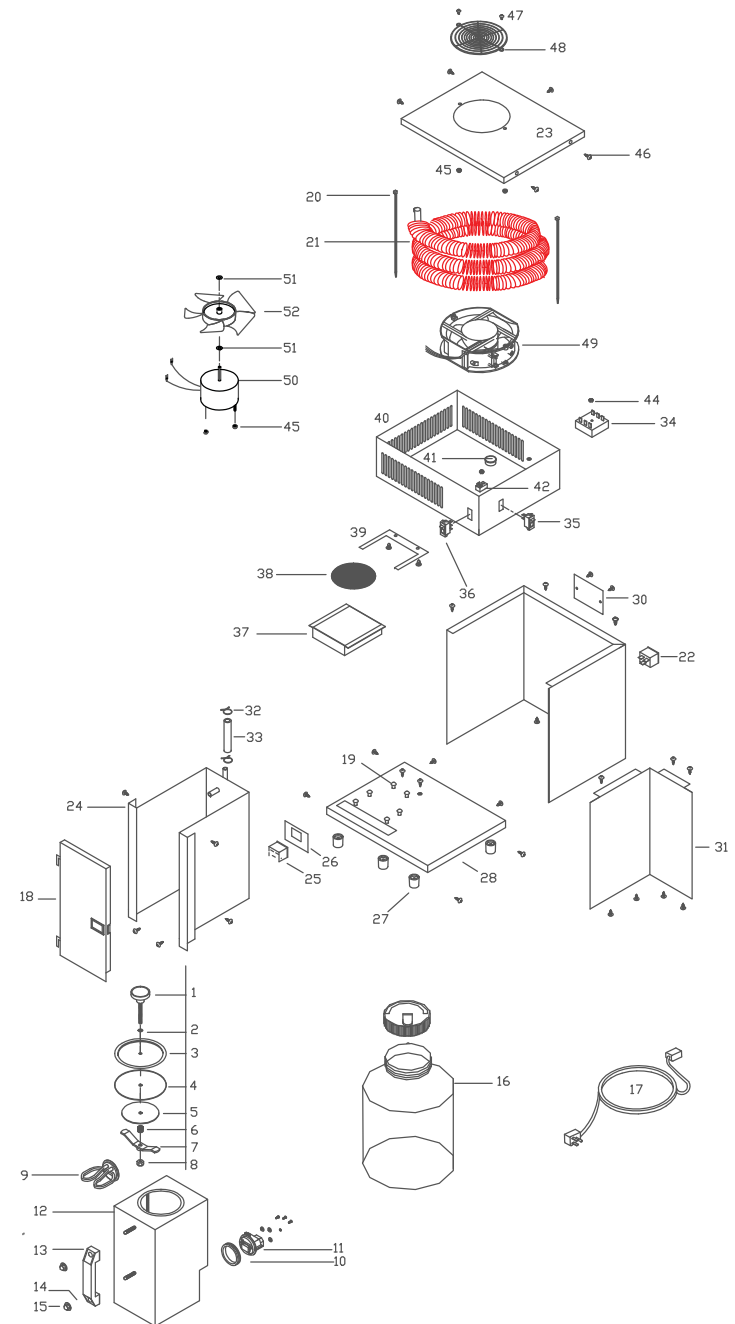

INDIVIDUAL PARTS LIST

Key #	Part #		Description
	120V	240V	
1			Lid Knob w/ Stud
2			Lid O-Ring
3			Lid Disc S.S.
4	69	69	Gasket, Boiling Tank Lid
5			Washer, Gasket Retainer
6			Spring, Tank Lid
7			Crossbar, w/ Nut
8			Nut, 1/4-20 Nylock
(1-8)	406	406	Lid Assembly Kit
9	9202A	9202AV	Heating Element, 750W-Otter Style
10	9205A	9205A	Seal, Silicon with Screws
11	9203A	9203A	Controller, Element-Otter Style
(9-11)	716B	716BV	Heating Element Kit-Otter Style
(10-11)	718B	718BV	Heating Element/Controller Kit-Otter Style
12			Boiling Tank, Studded
13	9108	9108	Handle, Black Plastic
14	9009	9009	Washer, 1/4", Stainless Steel
15	9039	9039	Nut, Acorn, 1/4-20
(9-15)	709B	709BV	Boiling Tank Assembly Kit
16	745	745	1 Gallon Jar w/Pour Lid
17	7276	NA	Power Cord, IEC
18	713A	713A	Door Assembly, Rectangle Latch
19	9148	9148	Riser, Pop-In
20	7246	7246	Wire Tie, Black
21	9217	9217	Condensing Coil
(20-21)	712	712	Condensing Coil Kit
22	7275	7275	IEC Connector
23	45014D	45014D	Top Cover
24	45504D	45504D	Boiling Tank Liner, Welded
25	9204A	9204A	Element Adapter
26	45024-02	45024-02	Clip, Adapter
27	9218	9218	Appliance Feet, 7/8"
28	45503C	45503C	Base, Studded
29	45008D	45008D	Cladding
30	45017B	45017B	Back Cover Plate
31	45009B	45009B	Middle Divider
32	9922	9922	Hose Clamp, Wire
33	9541	9541	Silicone Tubing
34	715	715V	Timer, 210 Minute
35	642	642	On/Off Switch
36	643	643	Start Switch
37	744	744	Filter Cup Kit
38	45518	45518	Carbon Filter, 4-Pack
39	45013A	45013A	Filter Holder, Square
40	45506E-02	45506E-02	Top Cabinet, Studded
41	9220	9220	1" Bushing, Closed
42	9111	9111	Terminal Block, 4-2-3
43	45016	45016	Insulation (not shown)
44	9070	9070	Nut, #10-24, Nylock
45	9003	9003	Nut, #8-32, Nylock
46	9029	9029	Screw, #10 Sheet Metal
47		9025	Screw, Fan
48	9342	9342	Guard, Fan
49	667	667BV	Fan, Box
50	45517	NA	Fan Motor
51	9092	NA	Push Nut
52	9216	NA	Fan Blade
(51-52)	711	NA	Fan Blade with 2 Push Nuts

CONGRATULATIONS

You've taken an important step to ensure that you and your family have fresh, great tasting high-purity drinking water.

The Pure Water Mini-Classic CT™ distiller is built of the finest materials and constructed with care and attention to detail. If you need assistance, please contact your local Pure Water Dealer or Distributor, or call Pure Water Customer Service at 1-800-875-5915 Ext 316. I urge you to take the time to read and understand the Safety Information section below.

We are sure you will have many years of use from your Pure Water Mini-Classic CT distiller. If you're as thrilled with this product as we expect you will be, we encourage you to tell a friend or neighbor?

Thanks for being a member of the Pure Water Family and helping us to "Improve the Quality of Life Through the Quality of Water!"™

Al Meder, President

IMPORTANT SAFETY INFORMATION

- Make sure the lid is removed from the glass jug before inserting into holding area, and before unit is turned on.
- Operate indoors only and allow at least 3 inches of clearance around unit when in operation.
- Always unplug the power before assembling, repairing or doing any work on the distiller.
- NEVER immerse the distiller in water or any other liquid.
- NEVER operate the distiller with a damaged cord or allow the cord to become exposed to hot surfaces.
- NEVER let children play with the distiller.
- Make sure your electrical outlet is properly grounded. If in doubt, contact a qualified electrician.
- NEVER remove the boiling chamber from the unit until it has cooled down.
- The physiological effect of the operation of this appliance, beneficial or otherwise has not been investigated by UL.
- Do NOT use with an extension cord.

USE AND CARE OF THE DRINKING WATER CONTAINER

To ensure proper performance and a lifetime of trouble-free service, please read the following information on general use and care of the drinking water container:

- Do not use on stove-top burner, under heating elements, in microwave or conventional ovens.
- Do not store hot liquids nor food in drinking water container.
- Dishwasher-safe Lid: Top rack only.

ELECTRICAL REQUIREMENTS

The Pure Water Mini-Classic CT must be plugged directly into a fully grounded outlet.

The Pure Water Mini-Classic CT will use approximately 8 amps when operating, so isolate a 10 amp fuse or circuit breaker for the unit.

This unit operates on 110V, 60 cycles, or as otherwise specified on the back of the distiller.

SYMPTOM: There is steam around the unit...

<u>Possible Cause</u>	<u>Check...</u>
INSUFFICIENT VENTILATION OF THE UNIT	...that the unit is not pushed hard against the wall. Keep a minimum of 2 inch clearance. ...if there are any items on the unit that may block the air flow. Remove any such items.

<u>Possible Cause</u>	<u>Check...</u>
FAN MOTOR	...if the fan is not turning and you have checked that there is power to the unit, and the timer switch is on, then it may be a failed fan motor. Replace the fan motor.

SYMPTOM: There is water around the unit...

<u>Possible Cause</u>	<u>Check...</u>
IMPROPER POSITIONING	...that the boiling tank lid is aligned with the boiling tank correctly. ...that the carbon filter is in proper position and water is flowing through it. ...that the drinking water container is correctly placed to catch the water. ...that the heating element and gasket are tight.

TROUBLESHOOTING

The Pure Water Mini-Classic CT distiller is designed for years of dependable service. The following guide is presented to assist you in the event of any problems with your

SYMPTOM: Unit does not produce water...

Possible Cause	Check...
NO POWER	<p>...that the power cord is plugged in and is pushed in completely to back of machine.</p> <p>...that the power to your home/office is on.</p> <p>...that the on/off switch (11) is turned on. Then press the "Start Cycle" switch.</p> <p>...that there is water in the boiling chamber.</p> <p>...that the boiling chamber (1) is completely</p>

Possible Cause	Check...
HEATING ELEMENT BURNED OUT	<p>...that there is power to your home/office...</p> <p>...that the power cord is plugged in and is pushed in completely to back of machine.</p> <p>...that the power switch is turned on...</p> <p>...that the boiling chamber is pushed in completely, and the fan rotates when the unit is on, but the air is cool, or cold...</p> <p><i>Then...</i></p> <p>Replace the heating element (stock#9202A).</p>

SYMPTOM: The distilled water has an off-taste...

Possible Cause	Action...
NEW CARBON FILTER NEEDED	<p>...change post filter by following directions for Replacing the Carbon Filter on page 11.</p> <p>...thoroughly clean the boiling chamber.</p> <p>Note: Make sure the boiling chamber is cool.</p>

HOW DISTILLATION AND YOUR MINI-CLASSIC CT WORK

Nature has a way to produce pure water from contaminated sea water. When the sun rises in the morning, it starts to heat the surface of the ocean. The heat causes molecules of pure water to evaporate (1) from the surface of the ocean and rise to condense (2) in the form of clouds. When the conditions are right, the clouds cannot hold any moisture and water precipitates (3) and falls to earth as rain. The rain collects in rivers, lakes and reservoirs and is available for drinking.

NATURE'S DISTILLATION CYCLE...

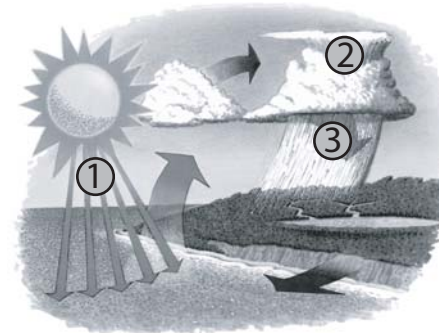

THE PURE WATER WAY...

A distiller operates the same way. Water is placed into a boiling chamber where heat is applied. The water boils and water molecules (steam) evaporate (1). The steam enters the condenser where cool air causes the steam to condense (2) it precipitates (3) as droplets of pure water. This water is collected and is fresh, great-tasting, distilled drinking water - the purest kind.

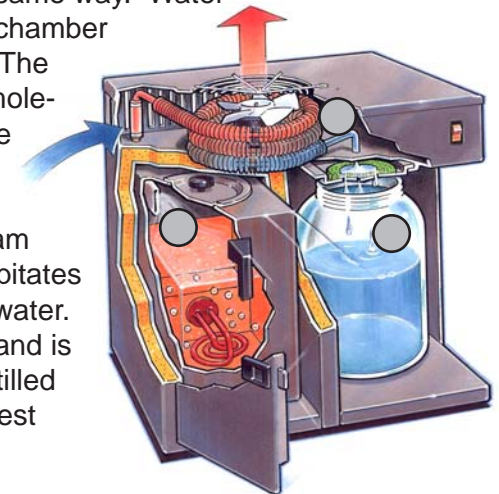

GETTING ACQUAINTED WITH YOUR MINI-CLASSIC CT

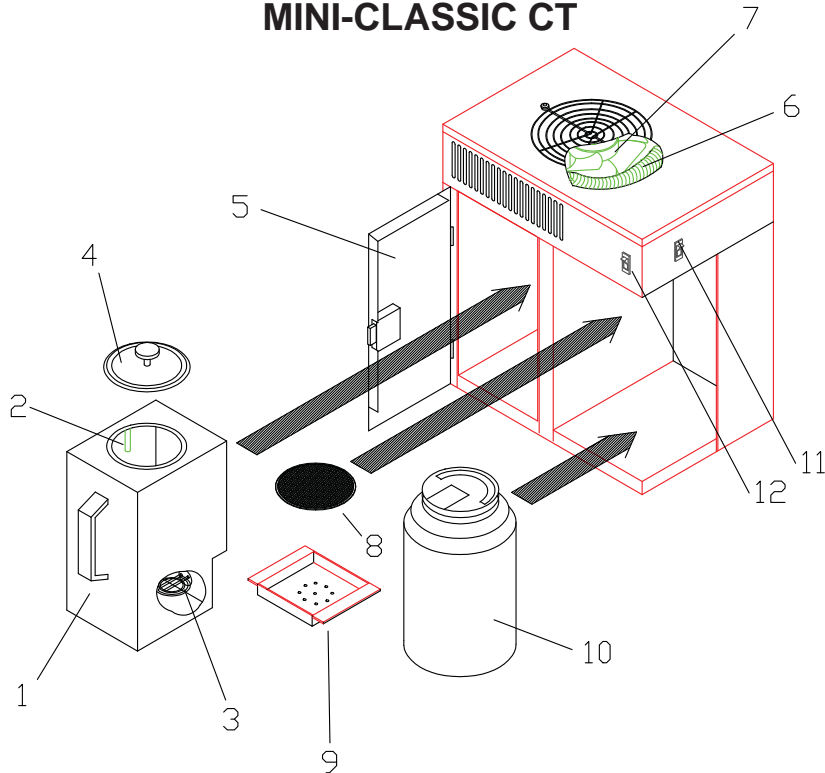

COMPONENT IDENTIFICATION

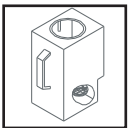

Boiling Chamber (1). The manually-filled stainless steel boiling chamber holds approximately one gallon of water when filled to the proper level.

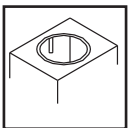

Water Level Indicator (2). A small rod which extends down into the boiling chamber. The boiling chamber should be filled to touch the bottom of this indicator. **CAUTION: DO NOT OVERFILL.**

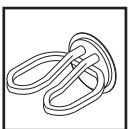

Heating Element (3). The 750-watt heating element provides the heat to boil the water in the boiling chamber.

To Clean the Boiling Chamber:

1. Turn the power switch to the OFF position.
2. If the unit has been operating, allow it to cool for 30 minutes from the end of the distillation cycle.
3. Carefully remove the boiling chamber from the unit.
CAUTION: The boiling chamber will get hot and could cause a burn if the unit has not been allowed to cool.
4. Remove the boiling chamber lid (4).
5. Drain any residual water inside the boiling chamber (1).
6. Fill the boiling chamber to the water level indicator (2).
7. Add Lumen™ Cleaner (stock #6603) to the boiling chamber. Follow instructions on the label.

Note: DO NOT replace the boiling chamber back into the unit during the cleaning process DO NOT allow the unit to operate with the Lumen Cleaner in the boiling chamber.

Replacing the Carbon Filter

A carbon filter (8) is used to finish or polish the water, and to improve the taste. The carbon filter should be replaced approximately every 3 months, or whenever the water develops a taste. The carbon filter is custom designed for the Pure Water Mini-Classic CT distiller.

To Replace the Carbon Filter:

1. Remove the drinking water container (10) from the unit.
2. Remove the old filter by sliding the filter housing (9) and filter (8) towards you or removing it from the opening in the drinking water container.
3. Immerse the new carbon filter (8) in a separate container filled with distilled water for one minute.
4. Remove the soaked filter and place it into the filter housing.
5. Slide the new filter and housing back into the guide.

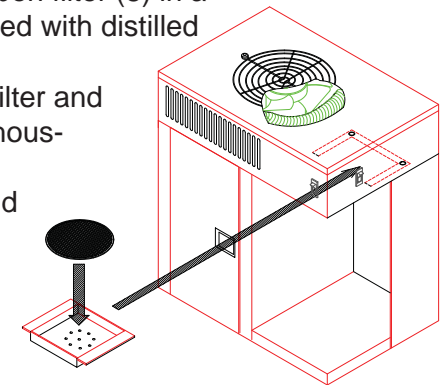

MAINTENANCE & CLEANING

With proper care on your part, your Mini-Classic CT will provide you with high-quality water for many trouble-free years.

The following recommendations are for typical water conditions. If you live in an area where the water quality is exceptionally poor, you may need to increase the frequency of our care.

Maintenance

Every Batch:

- Before each batch, swirl the residual water from the previous cycle, and rinse out the boiling chamber (1).

Monthly, or every 30 gallons:

- Clean the inside of the boiling chamber (1) to remove any buildup of solid residues. (See Cleaning below).

Every 3 months:

- Replace the carbon filter, stock #45518. (See page 11).
- Clean the exterior with Stainless Steel Cleaner & Polish, stock #6606.

Cleaning

Cleaning the Exterior:

Use Stainless Steel Cleaner & Polish (stock #6606) and follow instructions.

Cleaning the Boiling Chamber:

Sometimes scale will build up inside the boiling chamber. This needs to be removed periodically to ensure good heating element life, and high-quality drinking water.

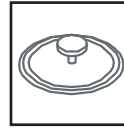

Lid (4). The lid is constructed of heavy-gauge stainless steel and has a special gasket and handle which tightens to seal when turned.

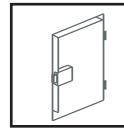

Door (5). The stainless steel door improves the look of the unit and serves an important safety role. DO NOT open the door until the unit has stopped distilling for a minimum of 30 minutes.

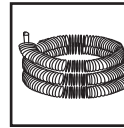

Condenser (6). A hollow, finned stainless steel tube where the steam from the boiling chamber is collected and cooled by the air from the fan. The steam is converted into high-purity drinking water. At the top portion of the condensing coil there are two small holes. These are two gas vents to allow volatile compounds to escape.

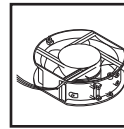

Fan (7). An electrical fan which works automatically to provide a flow of air across the outside of the condenser.

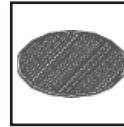

Filter (8). Before the distilled water flows into the drinking water container, it passes through an activated carbon filter pack to polish the taste of the water.

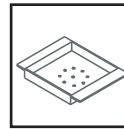

Filter Housing (9). A stainless steel housing designed to slide into the guides in the distiller and holds the carbon filter pack.



Drinking Water Container (10). This glass container collects the distilled water. It is equipped with a pour-through lid for ease of use.



Main Power Switch (11). Turns the unit on or off.



Cycle Start Switch (12). Pressing this switch will start the 210 minute distillation cycle.

UNPACKING YOUR MINI-CLASSIC CT

Your Pure Water Mini-Classic CT water purification system is shipped to you in a durable carton. Carefully remove the contents from the box.

The Pure Water Mini-Classic CT carton contains:

- The Pure Water Mini-Classic CT distiller.
- Glass container and lid.
- Filter kit.
- Owners Manual and Warranty Card.
- Power Cord (Not included in 240 Volt machines).

If these are not present, please look for the Quality Assurance Inspection Slip and note the name of the inspector. Call your Dealer or Distributor; or, in the event you can't reach them, contact Pure Water Customer Service Department at 800-875-5915 (outside the USA, please call 402-467-9300).

Note: Save the box and packing materials for future use in the unlikely event your Mini-Classic CT should require service work.

FIRST TIME START-UP

Starting the unit for the first time:

1. Open the door (5) and remove the boiling chamber (1) by pulling on the handle.
2. Remove the lid (4) by turning the black lid knob counter-clockwise and moving the lid (4) side to side and lift out.
3. Fill the boiling chamber (1) with cold tap water until the water touches the bottom of the water level indicator (2). DO NOT overfill.
4. Replace the lid (4) on the boiling chamber (1). Turn the black lid knob clockwise and tighten firmly, ensuring a good seal.
5. Push the boiling chamber (1) into the left side of the distiller until it fits snug and clears the blue decal.
6. Close the door.
7. Remove lid, and put the drinking water container (10) in place.

Note: DO NOT install the post filter at this time. Keep the first batch of distilled water for soaking the post filter.

First Time Start-Up Continued...

8. Plug the power cord into the back of the machine and then into the electrical source.
9. Turn the power switch (11) to the ON position.
10. Press and release the "Start Cycle" Switch.
11. Allow the unit to operate until it automatically shuts off (approximately 3.5 hours).
12. Keep the first batch of distilled water for soaking the post filter, but do not drink.
13. Submerge the filter (8) completely in a separate small container with distilled water for one minute, flip the filter several times.. Remove the filter (8) and place inside the filter housing (9).
14. Slide the filter housing (9) into the guide above the drinking water container.
15. Replace the drinking water container (10) to the distiller.

NORMAL OPERATION

1. Ensure that the boiling chamber is cool.
2. Open the door (5) and remove the boiling chamber (1) by pulling on the handle.
3. Loosen the black knob on the lid (4) and slide the lid from side to side and lift the lid out.
4. Swirl and empty out any water left in the boiling chamber (1) from the prior batch.
5. Fill the boiling chamber (1) with tap water until it touches the bottom of the water level indicator (2).
6. Place the lid (4) on the boiling chamber (1). Tighten the black lid knob firmly, ensuring a good seal. DO NOT overtighten.
7. Push the boiling chamber (1) into the left side of the distiller until it fits snug and clears the blue decal. Close the door.
8. Be sure lid is removed from container. Put the drinking water container (10) in place.
9. Turn the power switch (11) to the ON position.
10. Press and release the "Start Cycle" Switch.
11. Allow the unit to operate until it automatically shuts off. This will take approximately 3.5 hours and will produce approximately 3 liters of distilled water.

CAUTION: Never open the door during operation and never remove the boiling chamber while the unit is operating.