

Mega-25ST™



Operator's Manual

Form #6325A, ©2010, Pure & Secure LLC

Pure Water Brand
4120 NW 44th
Lincoln, NE 68524
Phone: 402-467-9300 • Fax: 402-467-9393

Table of Contents

Important Safety Information	3
Introduction.....	4
Record Important Information.....	4
Included With Your Distiller.....	4
Optional Accessories.....	5
How Your Distiller Works	6
Preparing for Installation	7
Installation	8
Connecting the Incoming Water Line.....	8
Connecting the Boiling Tank Drain Line & Overflow Line.....	10
Connect the Distilled Water Line and Faucet.....	11
Start-Up.....	12
Sterilizing	12
Post Filter Installation.....	12
Maintenance and Cleaning.....	14
Overall Maintenance Requirements.....	14
Cleaning the Boiling Tank	15
Changing the Post Filter	16
Troubleshooting.....	18
Electrical Schematic.....	21
Exploded View.....	22
Parts List	23

Parts Listing

Key # 120V P/N 240V P/N Description

1	8009	8009	Lid knob w/stud
2	6022	6022	Lid o-ring
3	519	519	Lid disc
4	6049	6049	Gasket
5	9009	9009	Flat washer, 1/4"
6	9085	9085	Lid spring
7	402B	402B	Lid crossbar w/nut
8	224-0003	224-0003	Locknut, 1/4-20
*	409	409	Lid Assembly (#1-#8)
9	6010	6010	Boiling tank gasket
10	7206	7206V	Relay, heating element
11	7208	7208V	Relay, storage tank
12	7227	7227	Momentary water switch (2 each)
13	7228	7228	ON/OFF switch (2 each)
14	7221	7221	Function switch
15	9039	9039	Cap Nut, 1/4-20
16	32028-02	32028-02	Tray, boiling tank, studded
17	9095	9095	Screw, 8-32 x 1/2"
18	7215	7215	Terminal strip
19	9043	9043	Hex Nut, 8-32
20	7217	1 72171	amp slo-blo fuse
22	32501B-02	32501B-02	Boiling tank, studded
23	9519	9519	Float ball
24	9018	9018	Hex nut, 6-32
25	514	514	Float rod
26	9024	9024	Set screw
27	9098	9098	Actuating arm
28	9080	9080	Float bushing
29	6021	6021	Float o-ring
30*	659	659	Float Kit (#23-#29)
31	7201	7201	Microswitch
32	9041	9041	Hex Nut, 4-40
33	9001	9001	Screw, 4-40 x 5/8"
34	9030	9030	Screw, 4-40 x 1-1/8"
35*	654	654	Microswitch Kit (#31-#33)
36	32023	32023	Boiling tank switch plate
37	9045	9045	Hex nut, 1/4-20
38	9032	9032	Lock washer, 1/4"
39	32006	32006	Boiling tank mounting bracket
40	8070	8070	Nylon spacer
41	9633	9633	Adaptor, STEM to BARB
42	7257	7257V	Automatic drain valve, NC
43	7230	7230	Cable holder, w/latch
44	9046	9046	Star washer, #10
45	6005	6005	Heating element gasket
46	7070	70100	Heating element
47	400A-02	400A-02	U-clamp w/stud
48	9009	9009	Flat washer, 1/4"
49	9061	9061	Hex nut, 10-24
50*	634	634V	Heating Element Kit (#45-#49)
51*	661	661	U-Clamp Kit (#47-#49)
52	508	508	Heat tab
53	7069	7069	Reset
54	510	510	Reset retainer board
55	32520-02	32520-02	Plate, reset retainer, studded
56	32007	32007	Boiling tank mounting angle
57	541	541	Fan motor mounting bracket
58	32504	32504V	Fan motor
59	7010	7010	Fan blade
60	9092	9092	Push nut
61	9003	9003	Lock nut, 8-32
62*	653	653V	Fan & Motor Kit (#58-#61)
63*	639	639	Fan Blade Kit (#59-#60)
64	9513	9513	Condensing coil
65	9530	9530	Compression ring, 3/8"

Key # 120V P/N 240V P/N Description

66	9510	9510	Compression nut, 3/8"
67*	626	626	Condensing Coil Kit (#64-#66)
68	9922	9922	Hose clamp, 19/32"
69	9541	9541	Silicone tubing
70	9921	9921	Hose clamp, 5/8"
71	8014	8014	Air Filter
72	9519	9519	Float ball
73	9018	9018	Hex nut, 6-32
74	525	525	Float rod
75	9091	9091	Storage tank actuating arm
76	9024	9024	Set screw
77	9080	9080	Float bushing
78	6021	6021	Float o-ring
79*	655	655	Float Kit (#72-#79)
80	39503A-02	39503A-02	Storage tank, studded
81	32022	32022	Switch mounting plate
82	7209	7209	Microswitch
83	9041	9041	Hex nut, 4-40
84	9001	9001	Screw, 4-40 x 5/8"
85*	660	660	Microswitch Kit (#82-#84)
86	9070	9070	Lock nut, 10-24
87	9094	9094	Flat washer, #10
88	95103	95103	Nylon hose BARB elbow
89	32505	32505V	Demand pump
90	9606	9606	Stem adaptor
91	9577	9577	3/8" tubing
92	9615	9615	Speedfit union elbow, 3/8"
93	32033	32033	Cladding access door
94	9029	9029	Sheet metal screw
96	9048	9048	Nut, hex, 1/8"
97	32037W-02	32037W-02	Stainless steel tray, studded
98	8011	8011	Appliance feet
99	95504	95504	Nylon elbow
100	9611	9611	Bulkhead union, 1/2"
101	9617	9617	Red collet cover, 1/2"
102	9618	9618	Blue collet cover, 3/8"
103	9612	9612	Bulkhead union, 3/8"
104	39036	39036	Pan, connection, SS
105	7219	7219V	Solenoid
106	7275	7275	IEC Female connector
107	7276	7276	IEC Power cord
108	32035A	32035A	Plate, switch, electrical
109	219-0227	219-0227	Hour meter
110	32029	32029	Bracket, safety float
111	213-0037	213-0037	Switch, level, safety
112	9627A	9627A	O-ring, 3/8"ID x 9/19"ID
113	9624	9624	Plug, 3/8"-16, NPT, SS hex head
114	110-9057	110-9057	Float, level control
115	32039	32039	Pump cover bracket
116	6070	6070	Grommet protector strip
117	36034	36034	Top Cladding w/slots
118	39031	39031	Cladding, right side panel
119	39032	39032	Cladding, wrap around
120	548	548	Lid, storage tank
121	402C-01	402C-01	Lid Crossbar, w/nut, storage tank
122	95315	95315	Faucet, Black, lock open
*	410	410	Storage Tank Lid Assembly
**	32050	32050	Boiling tank side insulation
**	32051	32051	Boiling tank bottom insulation

* parts kit ** not shown on exploded view

Important Safety Information

- If you are not sure that your electrical outlet is properly grounded or that the circuit protection is correct, have it checked by a qualified electrician.
- Operate indoors only.
- The area **MUST** be well ventilated.
- **WARNING:** Disconnect the distiller from the power supply before assembling, adjusting or servicing the distiller.
- **NEVER** immerse the distiller in water or any other liquid.
- **NEVER** operate the distiller with a damaged cord or allow the cord to become exposed to hot surfaces.
- **DO NOT** use an extension cord or adapters.
- **DO NOT** let children play with the distiller.
- **DO NOT** touch the top of the distiller when it is operating because it becomes very hot.
- Exercise care when removing the boiling tank lid and never remove it when the distiller is operating.
- The installation and use of this product must comply with all applicable state and local laws and regulations.
- **IMPORTANT:** This distiller is designed to be used only with Pure Water accessories and replacement components.
- This distiller is equipped with fused pump circuitry. In the event of pump failure, check the pump fuse located on the panel under the switches. Replace only with a 1 amp Slo-Blo fuse. Never use any fuse larger than specified.
- **NEVER** have the unit in the Auto Drain mode if an auto drain connection is absent.
- The physiological effects of the operation of this distiller, beneficial or otherwise have not been investigated by U.L.
- Operating Pressure 30-100 PSI
- Mega 25ST produces 12 gallons per day (0.5 gallons per hour) under normal operating conditions

Introduction

Congratulations on purchasing the finest water distillation system on the market. With proper care and attention, the Mega 25ST will give you many years of top performance and high-quality drinking water. Please read this manual thoroughly before installing and operating your Mega 25ST.

Record Important Information

The model and serial number are found on the back panel. You should record the serial number below for future references.

Date of Purchase: _____

Model: **Pure Water Mega 25ST**

Serial Number: _____

Purchased from: _____

Included With Your Distiller

In addition to your Mega 25ST distiller, your box will contain the following:

- Incoming Water Hook-up Kit. Includes:
Saddle tapping valve
3/8" T x 1/4" T speedfit elbow
15 feet of 1/4" food-grade tubing
- Drain Water Hook-up Kit. Includes:
Hose clamp
1/2" T x 1/2" STEM speedfit elbow
12 feet of 1/2" flexible tubing
12 feet of 1/2" high-temperature tubing
- Distilled Water Hook-up Kit. Includes:
Post filter
3/8" T x 3/8" STEM speedfit elbow
Filter bracket
25 feet of 3/8" food-grade tubing
6" faucet kit
3/8" T x 1/4" F speedfit connector
- Owners Manual and Warranty Card
- Storage Tank Faucet
- Manual Drain Kit
- Power Cord

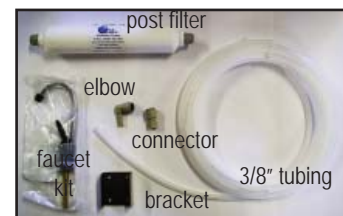
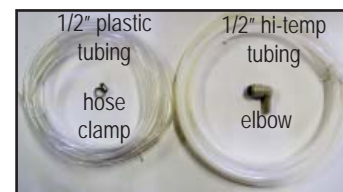

Exploded View

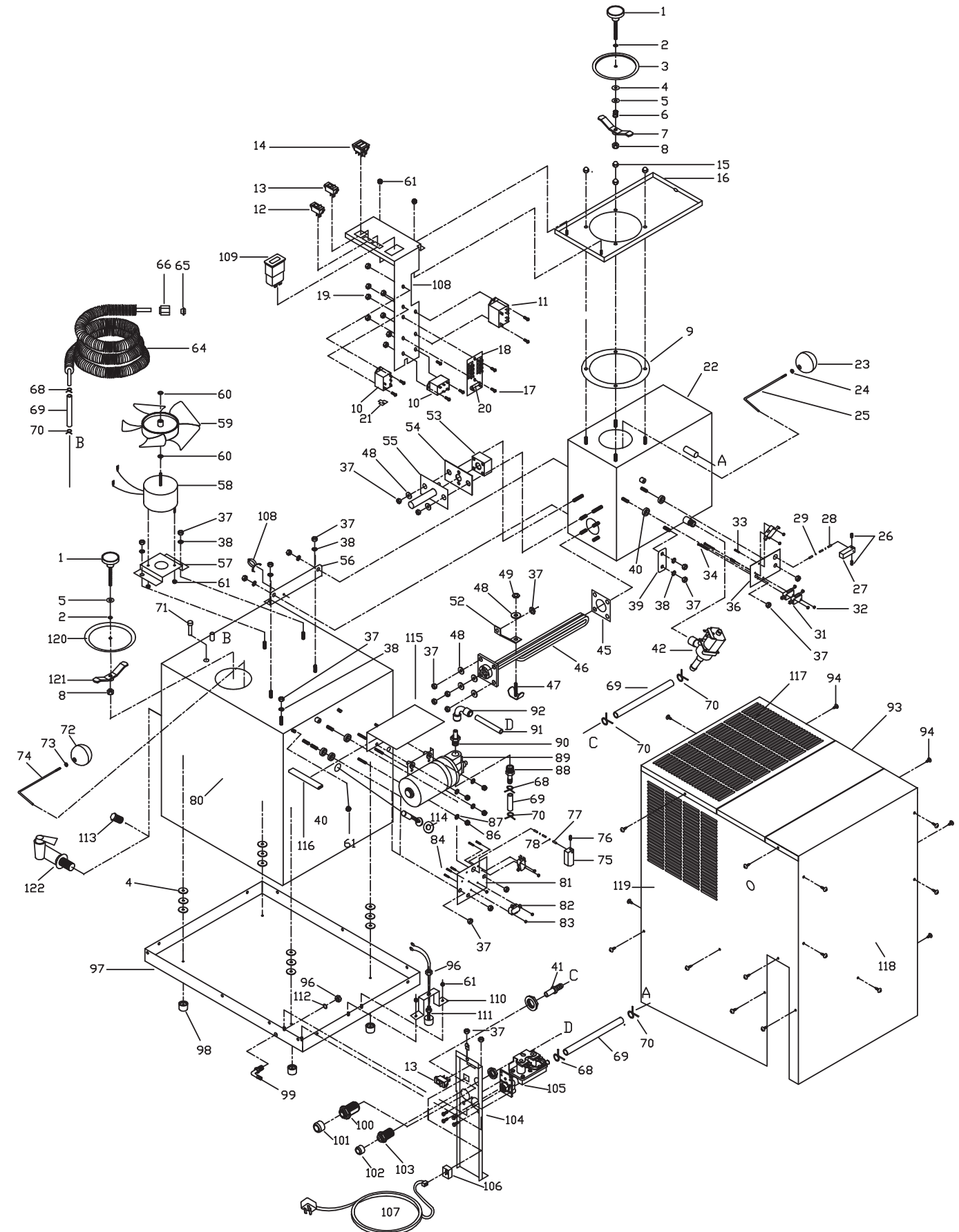

Electrical Schematic

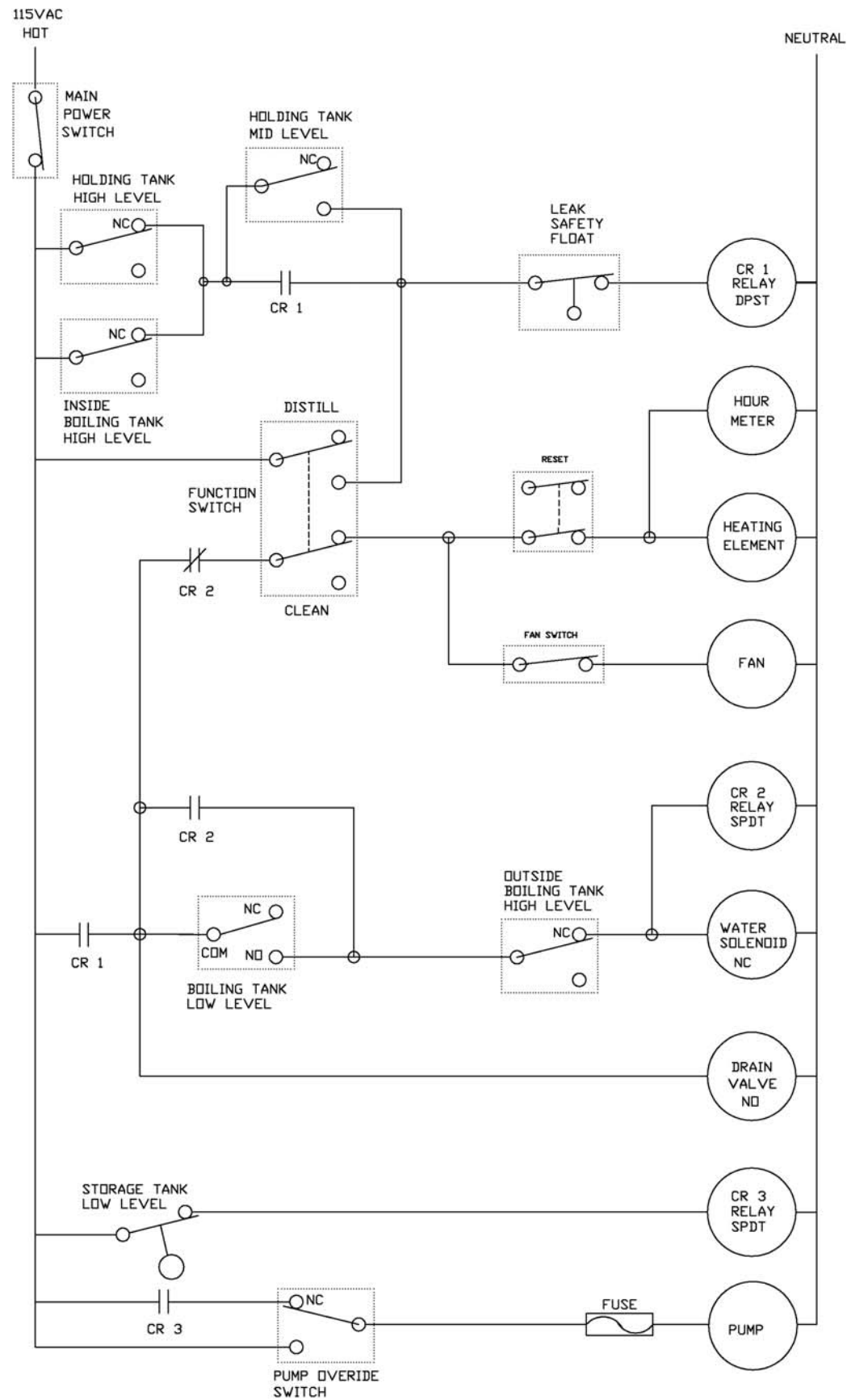

Optional Accessories

The following are optional accessories or maintenance items for the Mega-25ST. They may be purchased from your Dealer or Distributor, or directly from Pure Water.

- Auxiliary hook-up kit for running distilled water to your refrigerator or ice-maker. Stock #19009.
- Pressure tank hook-up kit to protect the pump when using with multiple dispensers. 19009B.
- Lumen™ cleaner and descaler for cleaning the boiling tank. Stock #6603.
- Stainless steel polish. Stock #6606.
- Post-filter replacement cartridge. Stock #32513.
- Extended-reach faucet for your sink (an option from the standard 6" faucet). Stock #95301K.
- Use a Pre-Filter (Stock #19051) if you plan to draw water directly from the distilled water tank through the Distilled Water Drain.

How Your Distiller Works

The Mega 25ST is designed to produce approximately one gallon of high-quality, pure distilled water every two hours, or up to twelve gallons in a 24-hour period.

The Mega 25ST is a fully automatic unit. The water level in the boiling tank and storage tank are controlled by individual floats and a set of microswitches.

Safety Feature

An overflow sensor is installed in the drip tray of your distiller in the unlikely event that a leak or an overflow situation occurs in your distiller. Your unit will automatically shut down when the switch senses a certain level of water in the drip tray.

Special Feature

An Hour Meter is installed on your Mega 25ST. This will allow you to track the operation and assist with scheduling maintenance.

The boiling tank operates on a modified batch approach. Feedwater is automatically added until a high level is reached and this triggers the heating element and fan to operate. This begins the distillation cycle.

As the unit distills, the water level in the boiling tank falls. When the water level gets close to the heating element, the low-level microswitch is triggered, causing feedwater to be added until the high level is reached. If, for some reason, no water enters the boiling tank when needed, the fan and heating element will remain off until the condition is corrected.

Once the storage tank is full of distilled water, the unit will automatically shut down and the contents of the boiling tank are drained by the automatic drain valve, thereby flushing out most of the contaminants from the boiling tank. If a drain is not available for automatic draining, the unit can be set to drain manually.

The Mega 25ST will begin distilling again once the water level in the storage tank drops to approximately 3/4 full. It continues to operate until the storage tank is full again.

The built-in demand pump allows distilled water to be delivered to a faucet, chilled/hot water dispenser, refrigerator, icemaker or other locations as desired.

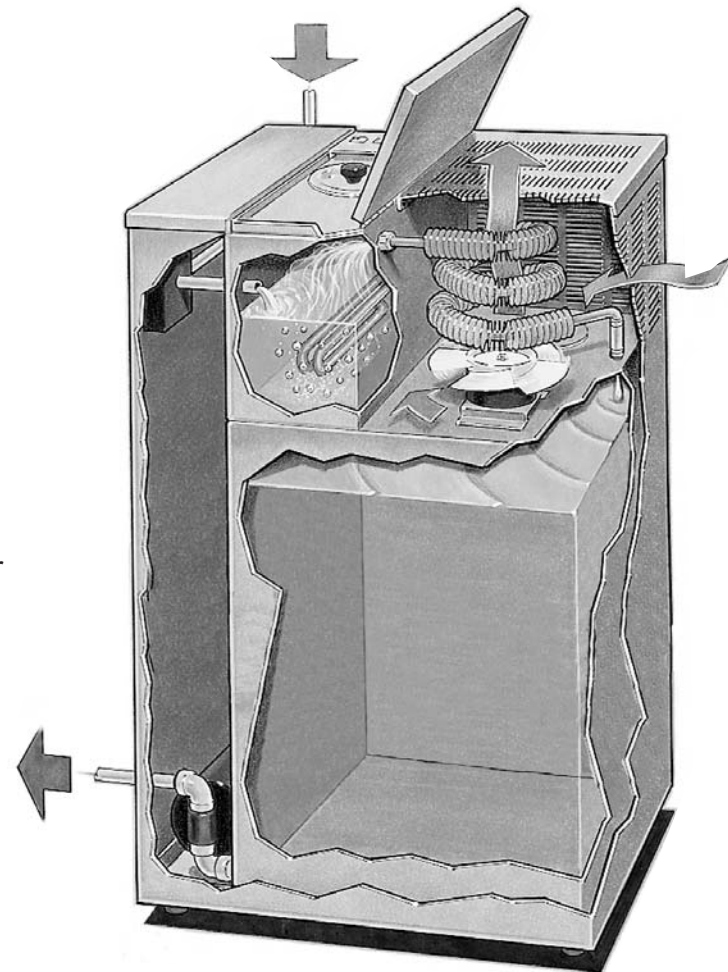

7

The boiling tank automatic drain valve does not open or shut.

- If water continues to drain during operation of the distiller, you may have a defective drain valve. Heavy scale may be preventing the drain valve from closing completely. Clean the boiling tank or replace the drain valve.
- If there is no water coming from the drain valve or it is draining slowly, you may have scale build-up in the drain valve or a defective drain valve. Clean or replace the drain valve.

8

The demand pump does not work properly or not at all.

Note: The storage tank must be at least 1/8 full for the pump to operate.

- If the unit is plugged in and the main power switch is "On", you may have a blown fuse, defective pump switch, defective pressure switch or defective pump. Check with a volt/ohm meter.
- If pump cycles on and off, but no water is delivered or it will not shut off after you close the faucet or cycles on and off when not in use, you may have leaks in your water line, a defective pressure switch, or defective pump.
- If pump does not deliver water to the faucet at a steady pressure, you may have a defective pump.

4

The distiller fills to normal operating level, but the heating element will not heat or bring water to a boil.

- If the reset is not popped or the fan is running and the boiling tank is full of water, you may have a defective heating element.
- If water continues to fill the boiling tank after draining the tank, and the fan isn't operating, then you may have a defective high-level boiling tank microswitch. Check with a volt/ohm meter.
- If the function switch is in the "Distill" position, the fan is not operating, you may have a defective function switch. Check with a volt/ohm meter.

5

The boiling tank overflows with water.

Note: If your machine is new, make sure you have removed the wire tie used to restrain the float during transit.

- If the float actuating arm is depressing the high-level microswitches (the bottom ones) and the float rod is moving freely and floats accordingly with the water level, you may have a defective microswitch. Check with a volt/ohm meter.

If the microswitches check out ok, and the heating element and fan come on, then you need to replace the heating element relay. Check with a volt/ohm meter.
- If the microswitches and heating element relay check out ok, then you may have a defective solenoid. Turn the main power switch to "Off". If water continues to flow into the boiling tank, then you need to replace the solenoid.
- If the float is not moving freely, you may need to install a new bushing and o-ring float repair kit.
- If the float ball is full of water, replace the float ball.

6

Machine does not shut off when storage tank is full.

- If the storage tank high-level microswitch is fully depressed, then you may have a defective microswitch. Depress both the boiling tank and storage tank high-level microswitches. If the unit does not shut down, remove one wire from the boiling tank microswitch. If the unit shuts down, replace the boiling tank microswitch. If the machine does shut down, leave the wire off and remove one wire from the storage tank high-level microswitch. If the unit shuts down, replace the storage tank microswitch.
- If the unit does not shut down when removing the wires from testing the boiling tank and storage tank microswitch wires, then you need to replace the main control relay.

Preparing For Installation

Before proceeding with the installation, you must determine the mode of operation (Auto Drain or Manual Drain). Pure Water recommends that your Mega-25ST be operated with the Auto Drain, but we recognize that all locations may not have an adequate drain available.

Note: The use of softened water is recommended to minimize scale build-up in the automatic drain valve.

Auto Drain Mode: This allows the boiling tank of the distiller to drain automatically when the storage tank is full or when there is a power interruption. The Mega 25ST needs to be installed in a location with an appropriate drain and drain connections, as explained in the Connecting the Boiling Tank Drain Line section on page 10 of this manual.

Manual Drain Mode: This allows the boiling tank to be drained manually. This is ideal for locations that do not have an appropriate drain or connection. The Drain Valve will not allow the unit to drain the boiling tank automatically. See Manual Drain Kit.

Other things to consider when installing your Mega 25ST:

- Select an area that will allow the distiller to remain level. Improper leveling could affect the production rate.
- The distiller must be located in close proximity to a water supply, floor or other drain and appropriate electrical supply source. The distiller should also be located in a well ventilated room.
- Electrical requirements: Isolated 115 VAC, 20 amp circuit (220 VAC, 10 amp). Check the electrical rating on the label on the rear of the distiller.
- When connecting the tubing into the quick-connect fittings, it is critical the tubing be inserted fully! The tubing should insert into the fitting 1/2" to 3/4". Failure to do so could cause water damage. We recommend that prior to inserting the tubing, you mark the tubing 1/2" from the end being inserted into the fitting, then pull back on the tubing to verify it is attached securely. This should ensure the tubing is properly and fully installed. Also, make sure the tubing is cut squarely and is free of rough edges.

Installation

Caution: The Mega 25ST is heavy. Please use caution during installation.

CAUTION: The Mega 25ST weighs approximately 75 lbs. Follow these instructions to prevent injury.

1. Open the carton from the bottom by cutting along the dotted line with a utility knife.
2. Carefully slide the carton up so the distiller is in the upright position when the carton is removed.
3. Remove and identify all parts kits as listed on page 4.

Connecting the Incoming Water Line

Notes and Cautions:

CAUTION: DO NOT use a hot water line for your supply line.

CAUTION: DO NOT turn the saddle tapping valve handle before or during installation. Be sure the piercing lance does not protrude beyond the rubber gasket. Failure to do this may result in damage to the piercing needle.

Note: The use of softened water for the raw water supply is recommended to minimize scale build-up in the boiling tank and automatic drain valve.

Note: The Mega 25ST comes standard with a saddle tapping valve. In some areas a saddle tapping valve may not be permitted. In such instances, contact your authorized Pure Water Distributor for other water line connection options.

Note: The use of softened water is recommended to minimize scale build-up in the boiling tank.

To hook-up the Incoming Water Line:

1. Locate the parts kit bag identified "Raw Water Hook-Up Kit".
2. Turn the household water supply OFF.
- 3a. For installation on **copper pipes**:
 - a. Assemble the saddle tapping valve on the cold water pipe so the outlet is in a convenient direction. See figure 1.
 - b. Tighten the screws evenly. The brackets should be parallel. Tighten firmly, but do not overtighten.
 - c. Connect the 1/4" plastic tubing to the saddle tapping valve.

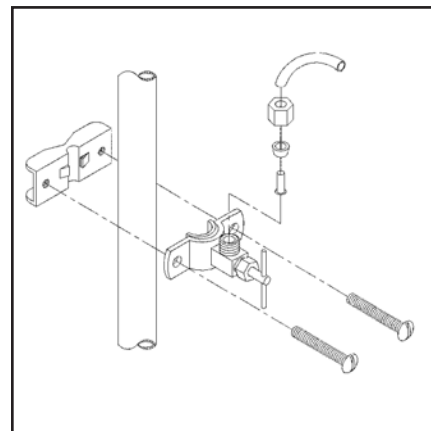

Caution: Never use the hot water line for your incoming water.

Troubleshooting

1

The machine will not operate at all.

Note: The water level in the storage tank must be below 7/8 full before the distiller can be restarted.

- Make sure the power cord is plugged into the wall outlet and the outlet is working properly.
- Make sure the main power switch is ON. If it is, the switch may be defective and needs to be replaced. Check with a volt/ohm meter.
- Make sure the function switch is in the "Distill" position. If it is, the switch may be defective and needs to be replaced. Check with a volt/ohm meter.
- Make sure the incoming water supply is turned on and is flowing into the boiling tank.
- Check for excessive water in the drip tray. Drain if necessary.

2

The boiling tank will not fill with water automatically.

Note: Make sure the saddle tapping valve or utility hook-up valve is turned ON to supply the feed water.

- If the float ball inside the boiling tank is resting against the support arm and is fully depressing the low-level microswitch, you probably need to replace the microswitch. Check with a volt/ohm meter.

If the microswitch checks out ok, and the heating element and fan come on, then you need to replace the heating element relay. Another indication of a bad heating element relay is the reset will pop.

- If the solenoid is making a buzzing noise, your feed water supply line may be clogged or you may have a defective solenoid valve. Check it with a volt/ohm meter.

3

The fan will not operate or is making excessive noise.

- If the fan is mounted properly on the storage tank, the fan blade is not loose around the motor shaft and the blade spins freely when turned by hand without hitting anything, then you may have a defective fan motor. Check with a volt/ohm meter.
- If the fan switch is in the "On" position, you may have a defective switch. Check with a volt/ohm meter.
- If the function switch is in the "Distill" position and the heating element is not operating either, you may have a defective function switch. Check with a volt/ohm meter.

Changing the Post Filter

1. Turn the main power switch to “Off” and open the auxiliary faucet at the sink to bleed the line of pressure. Close the faucet.
2. Have a bucket available to catch any excess water in the line. Remove the post filter by releasing the fittings on each end. Use care when removing the filter because you will need to reuse the fittings. Push in on the grey ring in the fitting, while pulling the tube out with the other hand.



Figure 5

3. Remove the fittings from each end of the post filter (see figure 5). Wrap the threads of each fitting with new Teflon tape, and install in the new filter cartridge. Tighten securely.
4. Connect the inlet side of the filter to the waterline.
5. Using a bucket, hold the filter outlet over the bucket. Turn the main power switch to “On” and allow water to flush the carbon fines out of the new filter. If the storage tank is low, depress the pump switch to “Override” to flush the filter.
6. Once flushed, turn the main power switch to “Off”.
7. Reconnect the outlet side of the filter to the waterline and turn the main power switch to “On”.

Caution: Never use the hot water line for your incoming water.

- d. Coil a minimum of 8 feet of tubing behind the distiller to allow it to be moved away from the wall for cleaning or service.
- e. Cut the required length of tubing to run from the saddle tapping valve to the distiller.
- f. Install the speedfit elbow onto the fitting marked “Raw Water In”. Pull to test.
- g. Connect the other end of the 1/4” plastic tubing to the elbow. Pull to test.
- h. Turn the saddle tapping valve handle clockwise until you feel it is firmly seated. Note: You have now pierced the water supply line and the valve is closed.
- i. Turn the handle counterclockwise to open the valve. Turn on the household water supply and check the connections for leaks. Tighten where required.

3b. For installation on **brass, steel, or PVC pipes:**

Note: Make sure the water supply is turned off and drain the line. Make sure you are using the COLD water line.

- a. Drill a 3/16” hole in the pipe. Use a hand drill to avoid shock hazard.
- b. Turn the saddle tapping valve handle to expose the lance beyond the rubber gasket no more than 3/16”.
- c. Assemble and place the body of the valve over the hole so the lance fits into the hole. Make sure the outlet is in a convenient direction. See figure 1.
- d. Tighten the screws evenly. The brackets should be parallel. Tighten firmly, but do not overtighten.
- e. Turn the saddle tapping valve handle clockwise to close the valve.
- f. Connect the 1/4” plastic tubing to the saddle tapping valve.
- g. Coil a minimum of 8 feet of tubing behind the distiller to allow it to be moved away from the wall for cleaning or service.
- h. Cut the required length of tubing to run from the saddle tapping valve to the distiller.
- i. Install the speedfit elbow onto the fitting marked “Raw Water In”. Pull to test.
- j. Connect the other end of the 1/4” plastic tubing to the elbow. Pull to test.
- k. Turn the handle counterclockwise to open the valve. Turn on the household water supply and check the connections for leaks. Tighten where required.

Connecting the Boiling Tank Drain Line & Overflow Drain Line

Notes and Cautions:

CAUTION: The boiling tank drain line delivers water in excess of 160° F to drain when actuated. Caution should be used when running this line to ensure safe placement of the tubing. The end of the tube should be secured to prevent movement during the draining cycle. If young children might be around the system, it is desirable to run the drain line through a large diameter piece of CPVC tubing which serves as a shield/insulator.

Note: Do not connect the drain line directly to a waste water drain, sewer or trap. Always allow an air gap between the drain line and the waste water to conform with local codes, and to prevent the possibility of waste water being forced back into the distiller. See figure 2.

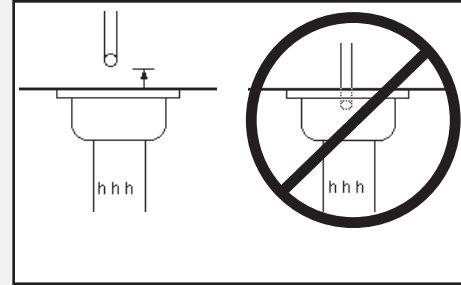

Note: If you are draining into plastic pipe, it must be rated CPVC at a minimum to handle the temperatures of boiling water. PVC is **unacceptable**.

Note: This unit, under normal operating settings, should be self draining. It is recommended that the distiller be installed with a proper drain. The location of the boiling tank drain outlet on the rear of the machine **MUST** be higher than the household drain. Failure to install the distiller properly could result in the unit draining hot water onto the floor. If your installation plans do not call for installing with a drain, you can manually close the drain by using the Manual Drain Kit. Pure Water cannot be responsible for any damage resulting from improper installation.

Caution: Always allow an air gap between the drain line and the waste water drain.

To hook-up the Boiling Tank Drain Water Line & Overflow Drain Line:

1. Locate the parts kit bag identified "Drain Water Line Hookup Kit".
2. Insert one end of the 1/2" high-temperature tubing into the 1/2" x 1/2" speedfit elbow. Press in firmly. Pull to test.
3. Insert the elbow into the red fitting on the back of the Mega 25ST marked "Boiling Tank Drain". Press in firmly. Pull to test.
4. Slide the 5/8" hose clamp onto the end of the clear, flexible 3/8" tubing. Install the tubing onto the elbow marked "Overflow Drain" on the lower rear of the unit. Tighten the hose clamp securely with a screwdriver.
5. Run the overflow drain line to the same location as the boiling tank drain line. Secure together if desired.
6. To hook up unit as manual drain operation, See Manual Drain Kit.

Cleaning the Boiling Tank

Notes and Cautions:

Caution: Under no circumstances should the cleaning solution be heated and run through a distillation cycle.

Note: If operating in the manual drain mode, you will need to drain the boiling tank once per week.

Note: Failure to clean the interior can result in:

- a) Scale build-up causing premature heating element or drain valve failure.
- b) Reduced purity of the distilled water due to the possibilities of splash over of contaminants from the boiling tank.

To clean the boiling tank:

1. Open the auxiliary faucet at the sink and remove enough water to restart the unit. This will be evident because the fan will turn on.
2. Open the top cover and move the function switch to "Clean". The fan will stop.
3. Carefully feel the boiling tank lid and check the temperature. If it is hot, wait at least 30 minutes for the unit to cool.
4. After the unit is cool, remove the boiling tank lid.
5. Add Lumen™ by following the directions on the package.
6. Add additional water using a jar or pitcher until the water level inside the boiling tank is above the scale line. **Caution: Do not overfill.**
7. Let the solution stand overnight.
8. After the scale has softened, turn the main power switch OFF. This will allow the boiling tank to drain. Once the boiling tank has drained, turn the main power switch ON and allow the boiling tank to refill. Turn the power OFF again, repeat this step several times to flush the boiling tank of cleaning solution and scale.
9. Return the function switch to "Distill". The unit is now ready for normal operation.

Note: If using the Manual Drain Kit, ensure that the manual drain valve is in the "open" position.

Note: If cleaning the unit without the automatic drain connections, ensure that you have a 3-gallon container or other method of catching the drain water.

23. Allow distiller to operate and fill up the storage tank. Distiller will shut off automatically. This will take approximately 60 hours.
24. Open the faucet and allow to run for 3 to 4 minutes to flush out the system. DO NOT CONSUME. Close the faucet. The pump should shut off and the machine will start-up.
NOTE: If pump does not shut off, you may have a leak in your water line.
25. You now have approximately 20 gallons of water in the storage tank for consumption.

Maintenance and Cleaning

If operated in the recommended automatic drain mode, the Pure Water Mega 25ST is designed for low maintenance performance. The Mega 25ST has a built-in drain valve that flushes the contaminants and residue out of the boiling tank after each full tank of distilled water is produced. This minimizes the build-up of scale in the boiling tank.

Overall Maintenance Requirements

The following guide should be used for the maintenance of your distiller. The timing will vary according to your local water conditions. It is your responsibility to maintain your equipment. Without proper maintenance, your distiller may not produce optimum results. The following times may be far too long for your particular area, so keep track of the average time and adjust the schedule below:

Every month* : Clean the boiling tank (see below).

* More frequent if water is hard

Every 3 months:

- a) **Change the post filter** (see page 16).
- b) **Clean the exterior.** Use Stainless Steel Polish & Cleaner (stock #6606). It is available from your Dealer or Distributor or from Pure Water.

Every 6 months:

- a) **Sterilize** (see page 12).

Caution: Never use copper tubing to run your distilled water line. It can leech into the distilled water.

Connecting the Distilled Water Line and Faucet

Notes and Cautions:

Note: Always use food-grade tubing (as included with the kit) for plumbing distilled water. **NEVER** use copper, as it can leech into the distilled water.

To hook-up the Distilled Water Line:

1. Locate the parts kit bag identified "Distilled Water Line Kit".
2. Insert the elbow into the blue fitting on the back of the unit marked "Distilled Water Out". Press in firmly. Pull to test.

Note: If you purchased a pressure tank for your Mega 25ST, please take note of installation instructions included with our Pressure Tank Kit now. If no pressure tank will be used, please proceed.

To hook-up the Faucet:

1. Locate the faucet included in the Distilled Water Line Hook-Up Kit.
2. Wrap the stem of the faucet with Teflon Tape and install the faucet at the desired point of dispensing as shown in figure 3. **Note:** The channel washer and stem nut should be tightened fully and be flush to the bottom of the sink top to hold the faucet in place.
3. Install the 3/8" speedfit connector onto the bottom of the threaded stem of the faucet.
4. Determine the correct length of 3/8" tubing needed to connect the outlet of the Distiller to the faucet. Cut and route the tubing to desired locations. We recommend that you secure the 3/8" waterline to the floor joists or other structure of the house to prevent the tubing from moving during water dispensing.

Note: Leave enough extra tubing to install the filter and to move the unit for cleaning.

5. Insert one end of the routed 3/8" tubing into the speedfit connector on the bottom of the faucet and the other end into the elbow labeled "Distilled Water Out" on the back of the distiller. Press in firmly. Pull to test.

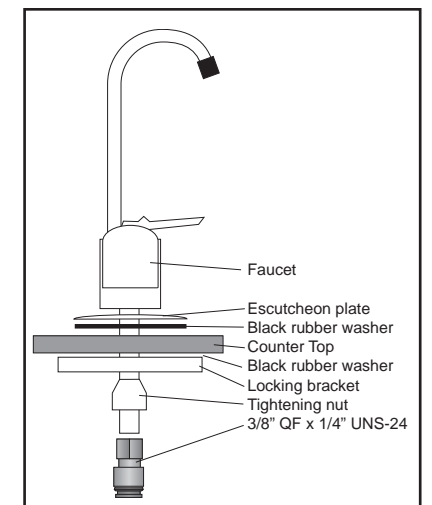

Figure 3

Notes and Cautions:

CAUTION: Do not, under any circumstances, cut or remove the round grounding prong from the electrical plug.

Note: Open the boiling tank lid and remove the wire tie restraining the float. This is used to prevent damage during shipment.

Note: This system must be fully grounded at all times. The electrical receptacle you use must be a fully grounded, single phase, AC 115-120 volt, 20 amp minimum circuit. If a two-pronged wall receptacle is encountered, it is the personal responsibility and obligation of the customer to contact a qualified electrician and have it replaced with a properly grounded three-pronged wall receptacle or have a grounding adaptor properly grounded. If an extension cord must be used, it should be a 3-wire, 20-amp minimum cord.

First-Time Start-Up, Rinsing, Sterilizing, and Filter Installation

Tools/Items Needed: 5 gallons of Distilled water at room temperature
Liquid chlorine bleach
Phillips screwdriver
Utility knife
Adjustable wrench

We recommend that you sterilize your Mega 25ST before putting it into use in order to eliminate any microorganisms that may have collected in the storage tank.

To sterilize your Mega 25ST:

1. Lift the access panel from the top of the unit. See figure 4.
2. Remove the top right vented panel by removing the three screws with a phillips screwdriver. See figure 4.
3. Remove the storage tank lid and set aside.
4. Pour in 2 1/2 gallons of Distilled water from the 5 gallon bottle into the storage tank.
5. Add 1 teaspoon of liquid bleach to the storage tank and mix well.

Caution: Do not add more than 1 teaspoon of liquid bleach into the storage tank.

Usage of safety glasses and rubber gloves is strongly recommended.

6. Replace storage tank lid and vented cover.



Figure 4

Caution: Do not install carbon filter until solution is completely drained.

7. Plug power cord into the machine and plug the distiller into the power supply.
8. Turn the main power switch ON.
9. Open the faucet for 15 to 20 seconds ensuring there is a steady stream of water, then close the faucet.

Caution: Do not consume this solution.

10. Check water line for leaks. Tighten where required.

Caution: If a leak is present, the pump may start automatically.

11. Allow the solution to remain in the system for 10-15 minutes.
12. Open the faucet and pump the remaining water from the storage tank. When the pump shuts off, press the "PUMP OVERRIDE" switch until no water is present. See figure 4a. Close the faucet.
13. Turn the function switch to DISTILL and the fan switch to STERILIZE. The fan will shut off. See figure 4a.
14. Allow to steam sterilize for 45 minutes to 1 hour.

Caution: For proper sterilization, unit must run for at least 45 minutes, but longer than 1 hour may harm the distiller.

15. Switch the main power to OFF. Unplug the distiller from the power supply.
16. Remove the top, right vented panel and the storage tank lid.
17. Pour the remaining 2 1/2 gallons of distilled water into the storage tank.
18. Replace the storage tank lid and vented panel.
19. Install the carbon filter.
 - a. At a location close to the Mega 25ST, install the post filter bracket using the tape installed on the bracket, or use a nail or a screw to affix to a wall.
 - b. Place the post filter into the bracket and ensure it is secure.
 - c. From the existing, distilled water line, cut the desired length of tubing to run from the back of the machine to the filter. Insert the tubing from the back of the machine to the inlet on the post filter. Insert the tubing from the faucet to the outlet of the post filter. Press in firmly. Pull to test.
20. Plug the unit into the power source and turn the main power switch ON.
21. Open faucet and pump out water from the storage tank until the pump shuts off. **DO NOT CONSUME THIS SOLUTION.**
22. Turn the fan switch to DISTILL. See figure 4a.



Figure 4a